

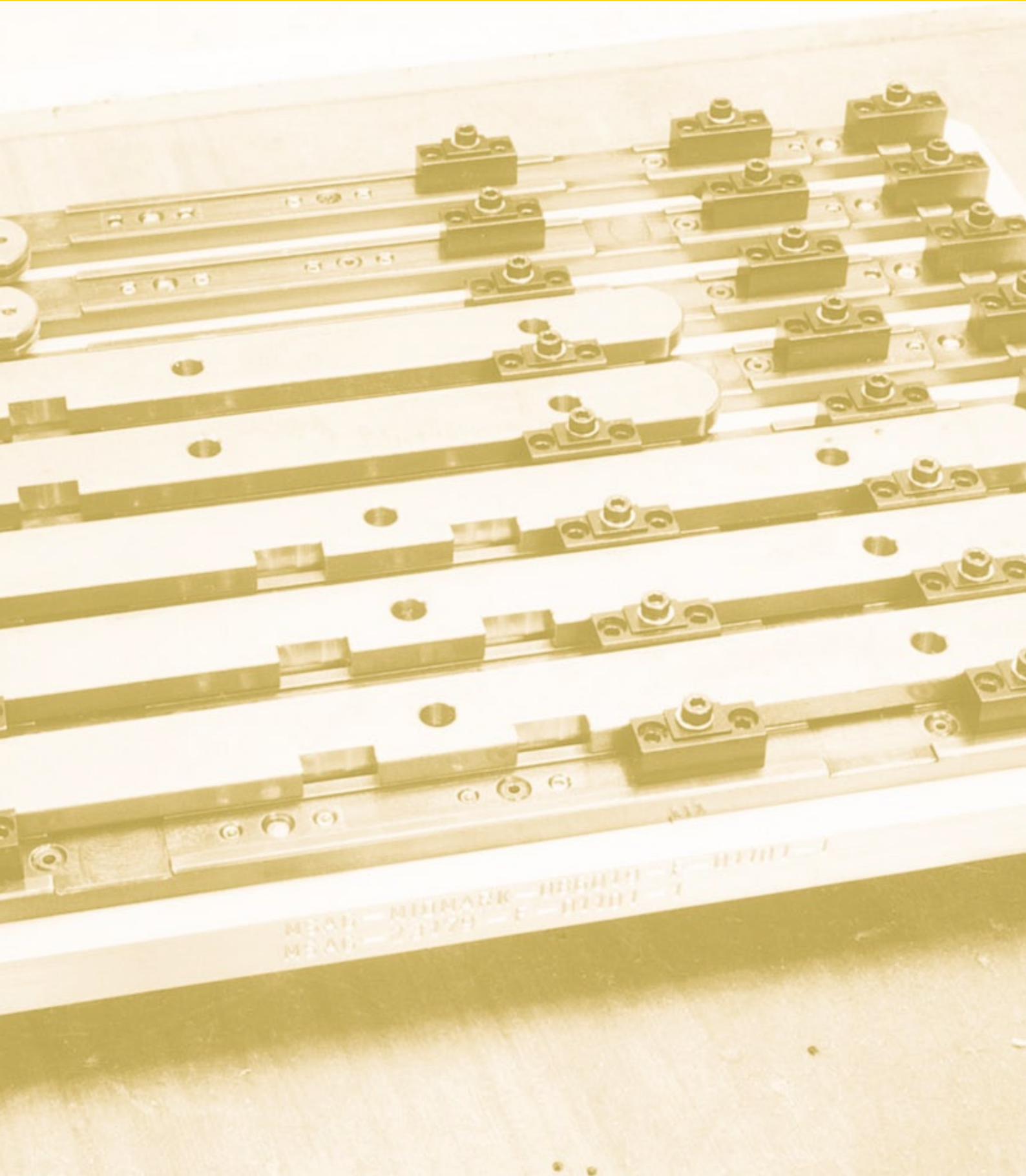

**micro**CLAMP



MEAS - MEDIMARK - 1111111 - 1 - 111111 - 1  
MEAS - 2/11/29 - 1 - 111111 - 1



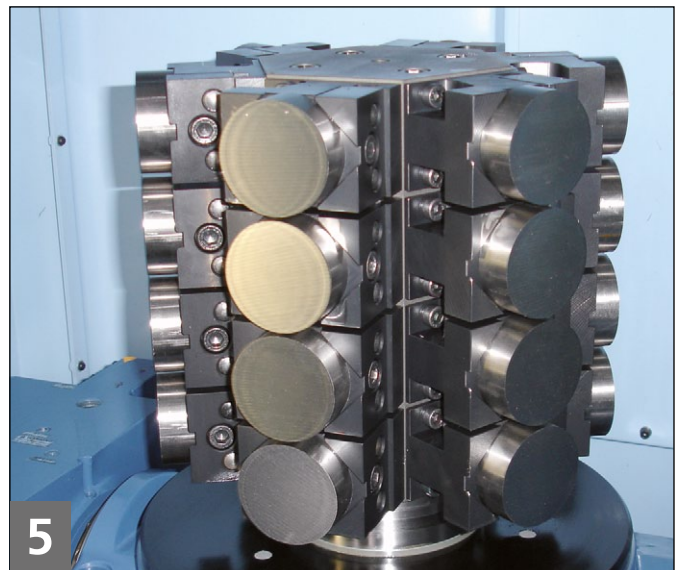
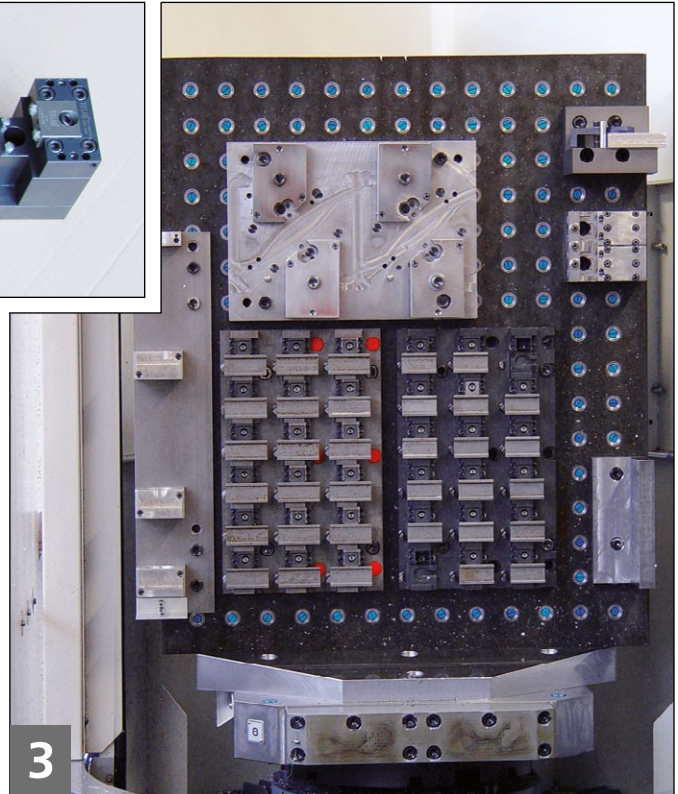
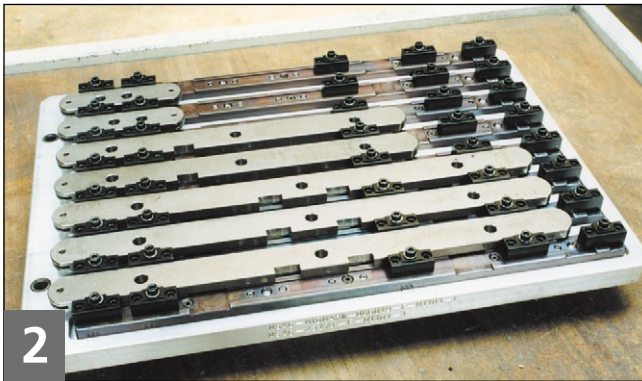
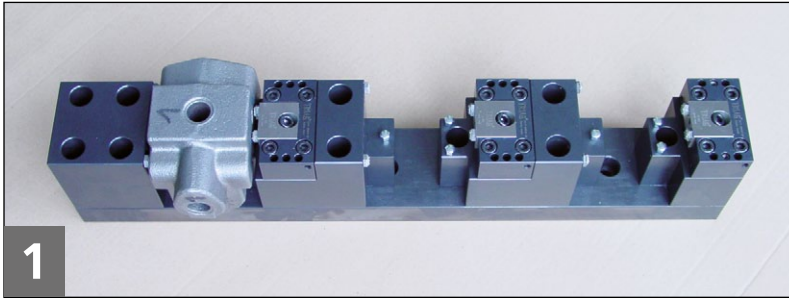



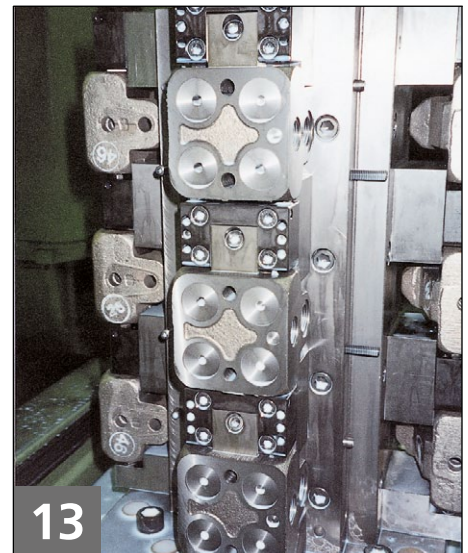
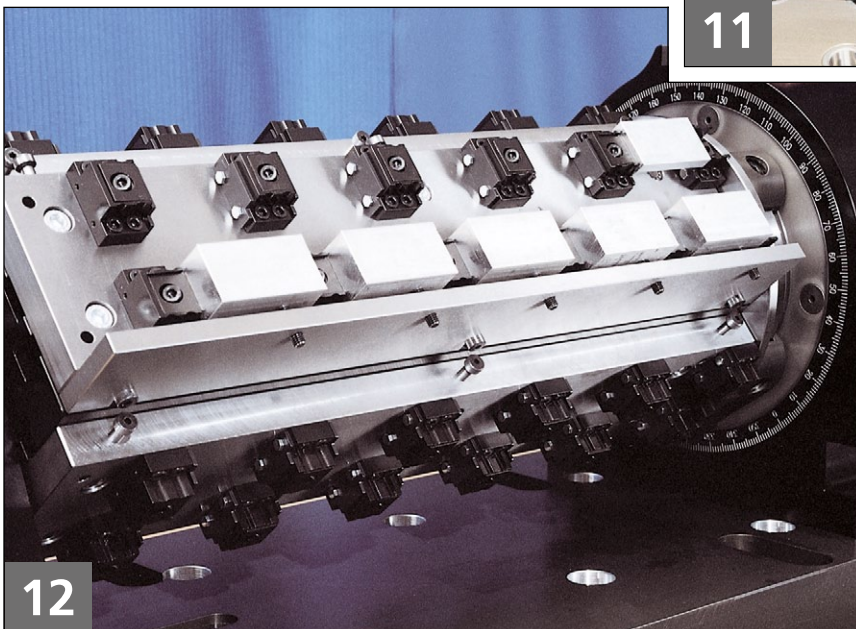
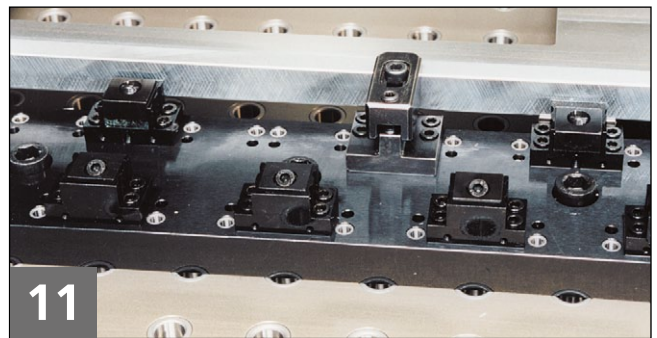
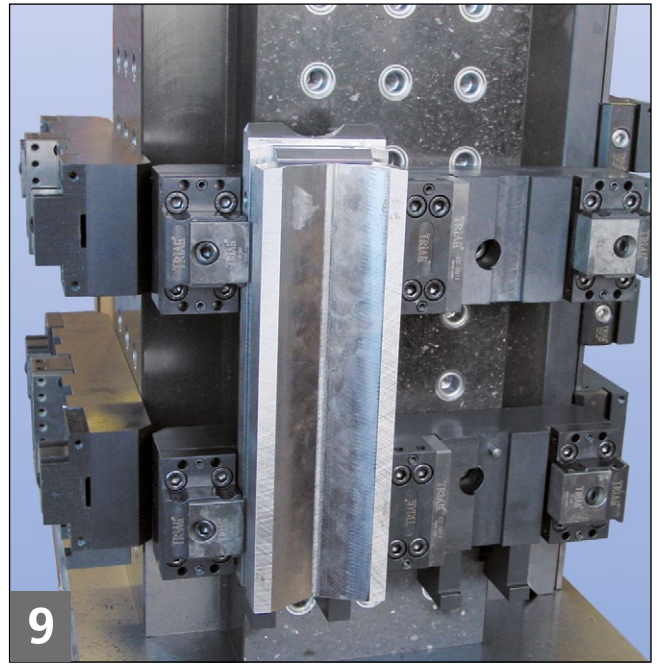
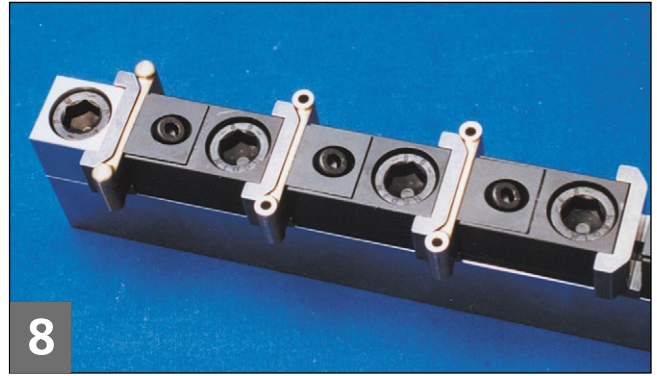
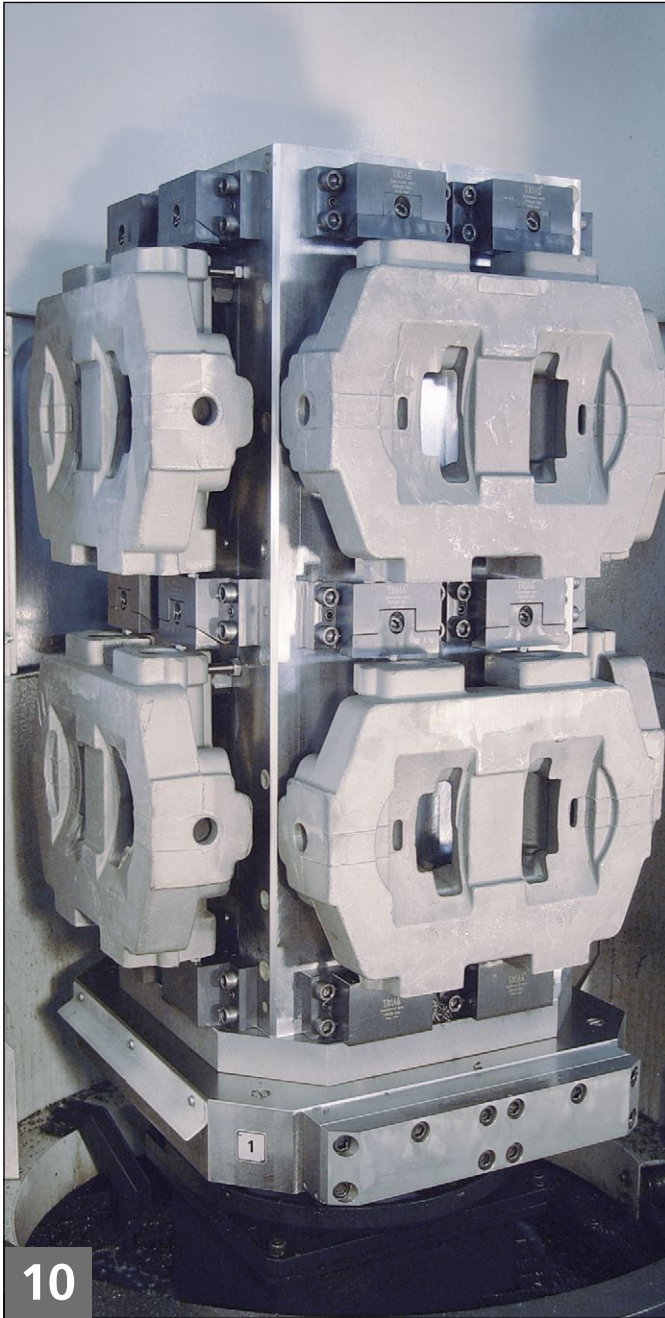



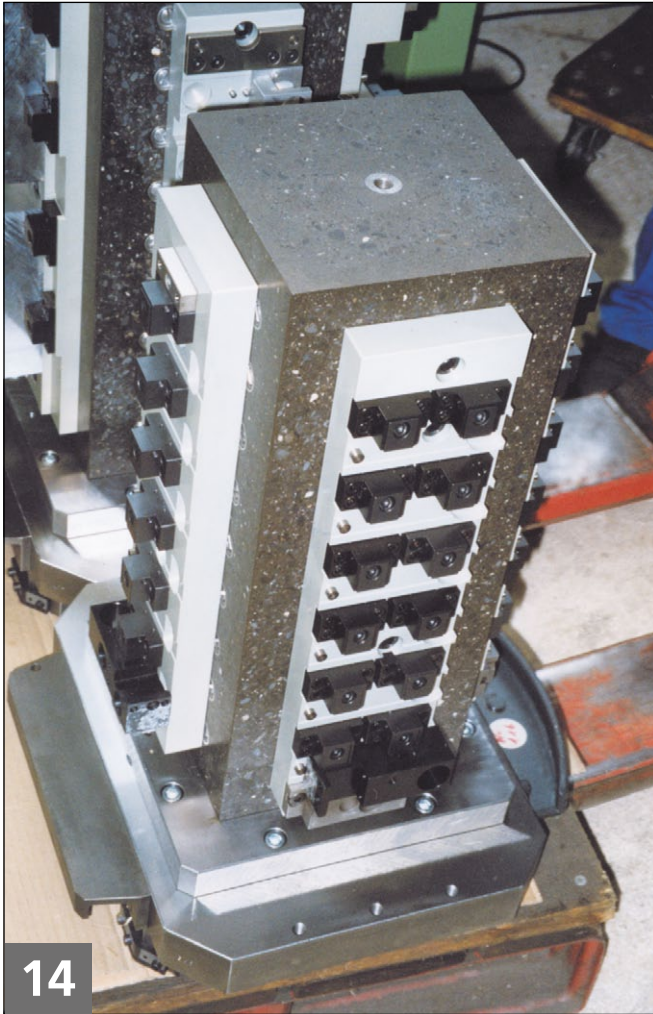

14



15

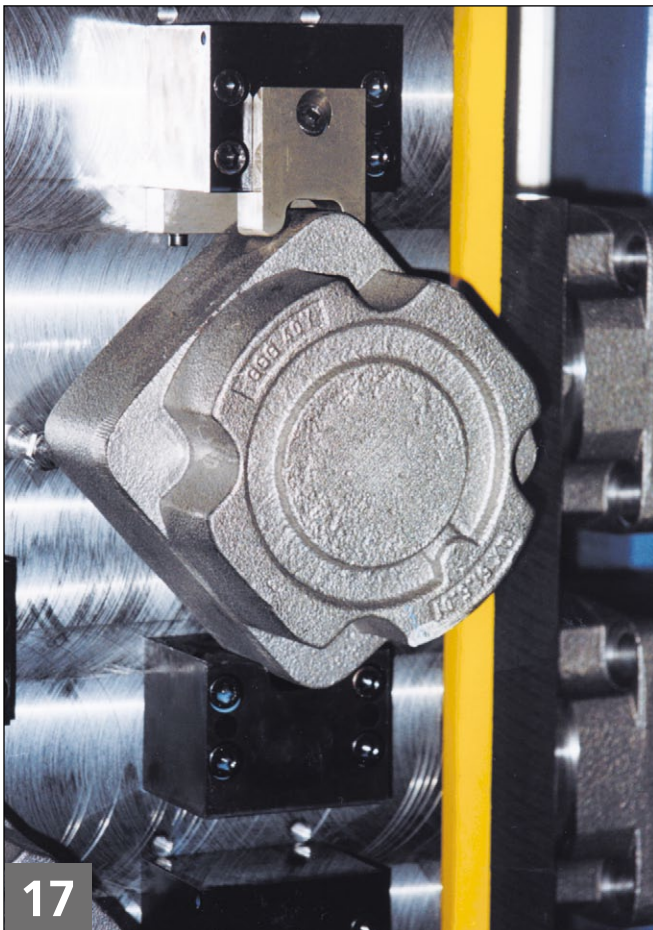

17

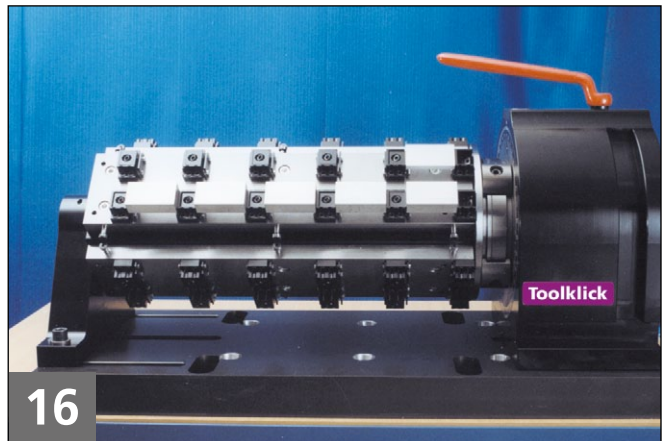

16

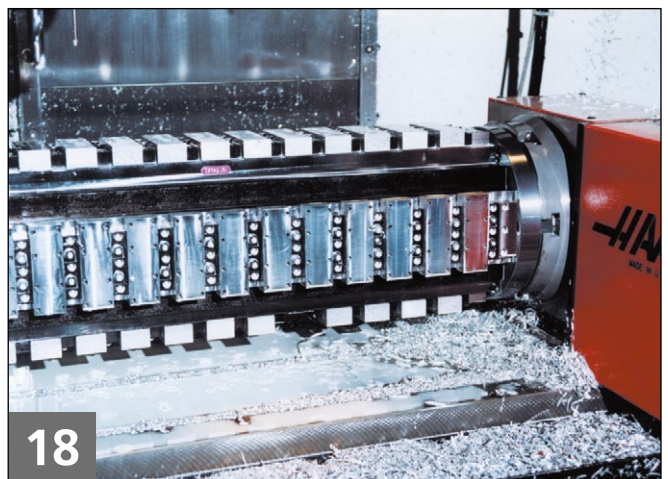

18



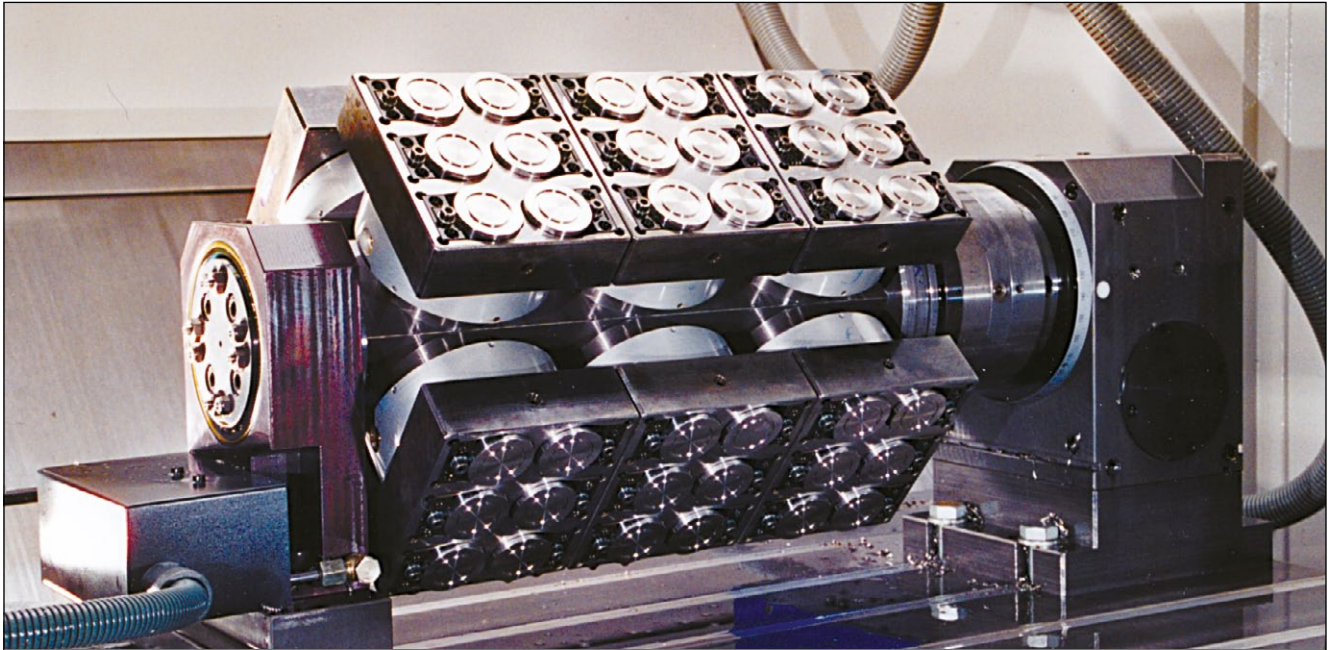

**19**

72 Teile sind hochgenau gespannt unter 10 my. Die Vorrichtungen sind auf einem EROWA ITS O-Punkt Spannsystem aufgebaut  
72 parts are clamped within 10 microns the clamp fixtures are set up on a EROWA ITS palleting system  
72 pièces sont serrées avec grande précision ( en dessous de 10 microns ). Le dispositif de serrage est monté sur un système de palettisation EROWA.

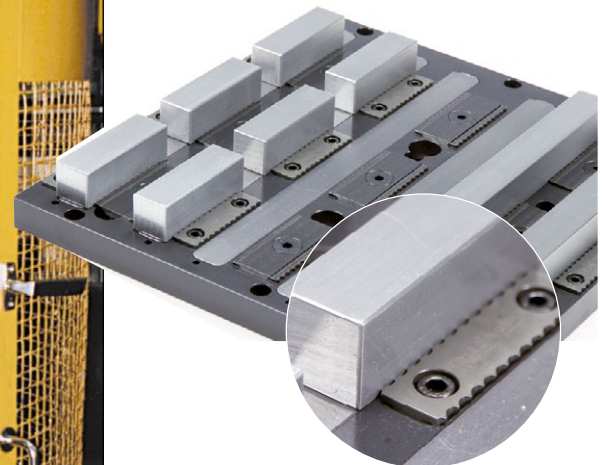

**20**

84 Teile sind gespannt mit Micro Clamp und werden jeweils nachts unbemannt produziert  
84 parts are clamped with Micro Clamp and are machined always at night unmanned  
84 pièces sont serrées avec les modules Micro - Clamp, idéal pour le travail de nuit sans surveillance.





**Kleinst-Spannmodule für den Vorrichtungsbau.**

**Extremely small clamping modules for dedicated fixtures.**

**Modules de serrage miniatures pour la construction de gabarits.**

**Hohe Spanndichte**

Die Spannmodule haben auf der Vorderseite eine Spannbacke, die Rückseite ist zu den Befestigungsbohrungen massgenau geschliffen. Damit kann diese Anschlagfläche für das folgende Werkstück genutzt werden. Diese Anordnung lässt eine sehr hohe Spanndichte zu. Beim kleinsten Micro Clamp-Modul sind nur 15 mm Spannabstand erforderlich.

**High workholding density**

*These clamping modules have a clamping jaw on the front, while rear is precisely ground with reference to the fixing holes. This means that it can be used as a datum face for the following workpiece. This arrangement allows very high clamping densities. Only 15 mm clamping clearance is needed between workpieces using the smallest Micro Clamp module.*

**Haute densité de serrage**

Ces modules de serrage sont munis d'un mors du serrage sur la face avant, la face arrière fonctionne comme surface d'appui pour la pièce suivante. Il est rectifié sur une face exactement par rapport à l'alésage. Donc il est possible de faire des gabarits avec une très haute densité de serrage. Les Micro Clamp les plus petits permettent une distance d'une pièce à l'autre de 15 mm seulement.

- Maximale Spannkraft der Module 2,8 t (28'000N)
- Benötigter Platz zwischen den Werkstücken ab 15 mm
- Spannhub ab 1,5 mm
- Genaue Positionierung durch Passschrauben und Positionierstifte

- Clamping force up to 2,8 t (28'000N)
- Space between workpieces only 15 mm
- Stroke of jaw from 1,5 mm
- Precise positioning by ground shoulder screws or dowel pins

- Force de serrage jusqu'à 2,8 t (28'000N)
- Distance entre les pièces à usiner à partir de 15 mm
- Course du mors à partir de 1,5 mm
- Positionnement exacte par vis d'ajustage ou des chevilles

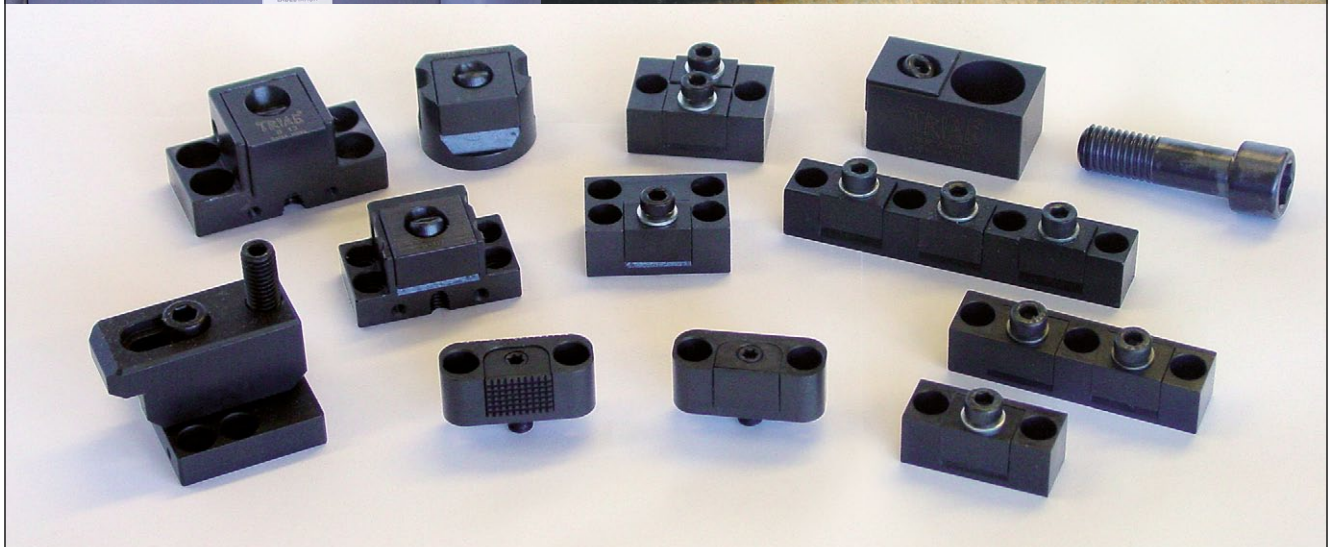
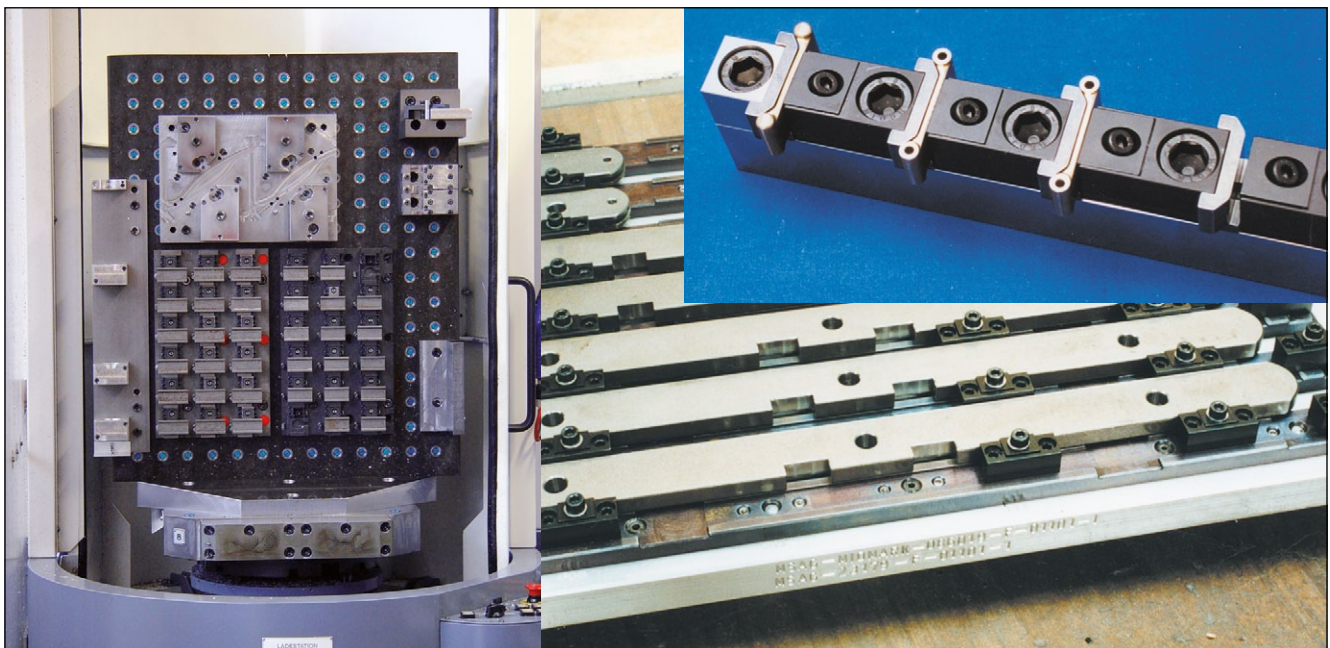





System System Système		bei Anschlagmodulen for end module pour module d'appui	Modulnutzbreite Module clamping width Largeur utile du module	Modulnutztiefe / -höhe Module clamping depth or height Profondeur ou hauteur utile du module
A	Apto Clamp	N nitriergehärtet <i>nitrated</i> nitrué		
P	Power Clamp	D durchgehärtet <i>through hardened</i> trempé		
C	Compact Clamp	<b>bei Spannmodulen for vice modules pour module de serrage</b>		
M	Micro Clamp	1 Anzahl Spannbacken 2 <i>Number of jaws</i> 4 Nombre de mors	19 25 26 34 43 48 58 61 68 78 94 125	<b>MS:</b> Tiefe <i>Depth</i> Profondeur  <b>VS:</b> Höhe <i>Height</i> Hauteur
V	Vorrichtungsbaumodule <i>Workholding modules for dedi- cated fixtures</i> Module de serrage pour gaba- rits individuels	- keine Spannbacke <i>no clamping jaw</i> sans mors de serrage		

**M S 1 F 35 N 14 B01**

Modultyp Type of module Type de module	
A	Anschlagmodul <i>End module</i> Module d'appui
S	Spannmodul <i>Clamping module</i> Module de serrage
T	Trägermodul <i>Supporting module</i> Module support
R	Rohling / Rundes Modul <i>Blank / Round module</i> Ébauche / Module ronde
V	Vertikalspannmodul <i>Vertical clamp</i> Module de serrage vertical

Anschlagfläche der Module Datum face Surface d'appui	
F	Anschlagfläche glatt <i>Datum face flat</i> Face d'appui lisse
R	Anschlagfläche geriffelt <i>Datum face double serrated</i> Face d'appui striée en croix
D	eine Seite glatt, eine Seite geriffelt <i>one face flat, one face double serrated</i> une face lisse, une face striée en croix
G	Anschlagfläche gerillt <i>Datum face serrated</i> Face d'appui strié
X	spezielle Ausführung <i>special execution</i> exécution spéciale
5X	5axes Clamp
P	prägen
PV	<i>stamping</i>
P6	imprimer

Backenhub Stroke of clamping jaw Course du mors de serrage	
N	Niederzug <i>Pull down</i> Abaissant
L	linear / parallel <i>linear / parallel</i> linéaire / parallèle
-	ohne Spannbacke <i>no clamping jaw</i> sans mors de serrage

Spannbackentyp type of clamping jaw type du mors de serrage	
B01	Spannbacke
-	<i>Clamping jaw</i>
B99	Mors de serrage
-01	Modul ohne Zubehör
-	<i>Module without accessories</i>
-105	Module sans accessoires
W	weich / <i>soft</i> / doux
F	glatt / <i>flat</i> / lisse
PRG	Prägebacke
PRGV	<i>Stamping jaw</i>
PRG6	Mors d'impression





# ACHTUNG / CAUTION / ATTENTION

**WICHTIG:** Die im Micro Clamp Kapitel angegebenen Drehmomente sind die absoluten Maximalwerte. Über die Spannkräfte gibt die untenstehende Tabelle Auskunft.

**IMPORTANT:** The torque numbers specified in the Micro Clamp chapter represent the absolute maximum. The table at the bottom of this page provides further information on the workholding forces.

**IMPORTANT:** Les valeurs des couples de torsion mentionnées dans le chapitre Micro Clamp sont les valeurs maximales absolues. Pour les forces de serrage vous pouvez vous référer à la table ci-dessous.

MC-Module	Schraube Screw Vis	Drehmoment max. Torque max. Couple de torsion max.		Spannkraft max. Workholding force max. Force de serrage max.		
		Nm	(lb-ft)	daN	(lb)	t
MS2P (MS2P) 58L14 PRG15	M8 (linear / linéaire)	15	11	600	300	0,6
MAND 58-14 PRG	M8	8	5,9	730	1600	0,73
MS2F (MS1F) 58L14 W251	M8 (linear / linéaire)	15	11	600	33	0,6
MANF 58-14 W25 (N25)	M8	8	5,9	730	1600	0,73
MV1F 20L35 BV1	M6 (linear / linéaire)	15	11	920	2070	0,92
MR1F 30N23 -07	M5	10	7,4	1020	2240	1,02
MS1F 22N40 -07		10	7,4	1020	2240	1,02
MS1F 24N22 -07		10	7,4	1020	2240	1,02
MS1R/F 25N25 -13	M6	15	11	1520	3340	1,52
MS1F 35L14 -150	M6 x 0,5 (linear / linéaire)	10	7,4	570	1260	0,57
MS1F 35N14 -01	M5	10	7,4	1020	2240	1,02
MS1F 35N22 -01		10	7,4	1020	2240	1,02
MS2X 25N23 -01		10	7,4	1020	2240	1,02
MS2F 60N14 -01		10	7,4	1020	2240	1,02
MS3F 85N14 -01		10	7,4	1020	2240	1,02
VS1R 19N35 -20	M6	15	11	1520	3340	1,52
VS1R 26L35 -31	M8 (linear / linéaire)	25	18,4	2100	4600	2,10
VS1R 26N35 -26	M8	25	18,4	2100	4600	2,10
VS1R 38N50 -60		25	18,4	2100	4600	2,10
VS1R/F 41L30 -51	(linear / linéaire)	25	18,4	2100	4600	2,10
VS1R/F 41N30 -60		25	18,4	2100	4600	2,10
VS1R/F 80L30 -51	(linear / linéaire)	25	18,4	2100	4600	2,10
VS1R/F 80N30 -36		25	18,4	2100	4600	2,10
VS1R 80N50 -36		25	18,4	2100	4600	2,10
VS1R/F 80N30 -60		25	18,4	2100	4600	2,10
VS1R 80N50 -60		25	18,4	2100	4600	2,10
VS1R/F 125N49 -95	M10	40	29,5	2800	6150	2,80
VS2R 80N30 -60		25	18,4	2100	4600	2,10
VS2F 90N30 -60		25	18,4	2100	4600	2,10
VS1X 59L60 K	(linear / linéaire)	50	37	1880	4180	1,88
VS1X 59L60 H5	(linear / linéaire)	50	37	1640	3640	1,64

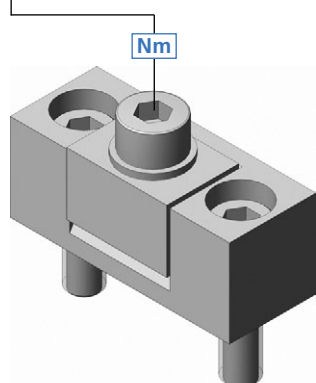

**Spannbacken und Schrauben regelmässig fetten!**  
**Lubricate clamping jaw and screws regularly with grease!**  
**Lubrifiez le mors et les vis régulièrement!**

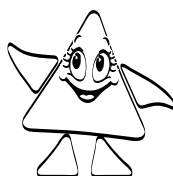

M5 + M6	4	3	500	1100	0,50
	5	3,7	580	1300	0,58
	6	4,4	690	1500	0,69
	7	5,2	780	1700	0,78
	8	5,9	880	1930	0,88
	9	6,6	980	2150	0,98
	10	7,4	1020	2240	1,02
M6	12	8,9	1220	2680	1,22
	14	10,4	1450	3200	1,45
	15	11	1520	3340	1,52
M8	4	3	410	900	0,41
	5	3,7	490	1080	0,49
	6	4,4	560	1200	0,56
	7	5,2	660	1450	0,66
	8	5,9	730	1600	0,73
	9	6,6	810	1790	0,81
	10	7,4	900	1980	0,90
	15	11	1520	3340	1,52
	20	14,8	1810	4000	1,81
	25	18,4	2100	4600	2,10
M10	10	7,4	400	890	0,40
	20	14,8	1400	3080	1,40
	30	22,1	2000	4400	2,00
	40	29,5	2800	6150	2,80



# Vorrichtungsbau – Prägemodule

## Fixture construction – stamping modules

### Construction de gabarits – mors d'impression



**microCLAMP**

Keilspanner in weicher Aus- *Double angle clamps with soft* Modules de serrage doux pour  
führung zum Bearbeiten von *jaws for making shaped forms.* l'exécution de formes différentes  
Formbacken.

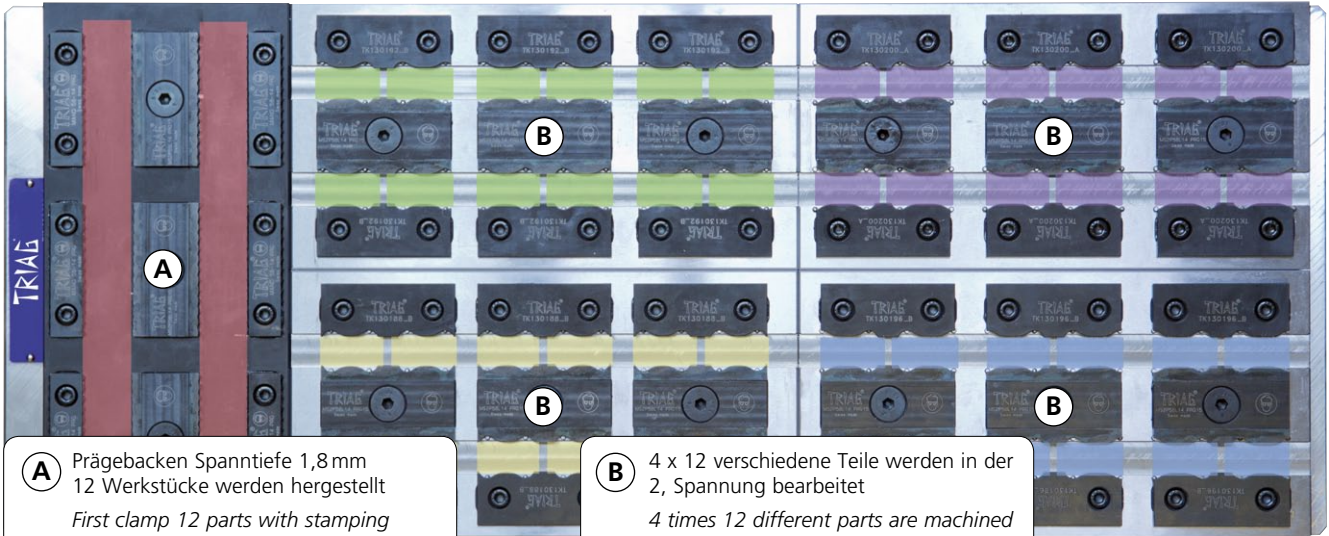

**A** Prägebacken Spanntiefe 1,8mm  
12 Werkstücke werden hergestellt  
*First clamp 12 parts with stamping  
jaws clamping depth 1,8mm*  
Mors d'impression profondeur de serrage 1,8mm 12 pièces sont produites

**B** 4 x 12 verschiedene Teile werden in der  
2. Spannung bearbeitet  
*4 times 12 different parts are machined  
in the second operation*  
4 x 12 pièces différentes sont usinées  
(2 pièces par modules)

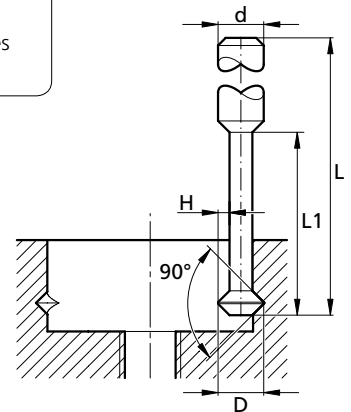

45°		d	D	L1	H	z	L
TK150057_A	A90 MT8	6	6,0	24,0	1,5	3	58

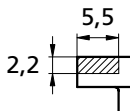

**Zum Erstellen Ihrer individuellen Formbacke:**

Schnittzeichnung zum Ermitteln der maximalen Bearbeitungsprofiltiefe

für / for / pour \*TK120529

**If a dedicated jaw is being machined:**

*This sketch will be of help regarding the workpiece penetration depth*

**Pour régler votre mors individuel aux étages:**

Dessin en coupe pour déterminer la profondeur maximum du profil à usiner

Fertigungsmasse für die Vorrichtungplatte:

**Machining data for the fixture plate:**

Cotes d'usinage pour la plaque de base:

Seite / Page 136 ►





Fertigungsmasse für die Vorrichtungplatte: / Machining data for the fixture plate: / Cotes d'usinage pour la plaque de base:

<p><b>Mass</b> X (X1) = B + 24 mm <b>Beispiel:</b> Bauteilbreite = 14 mm</p>	<p><b>Dimension</b> X (X1) = B + 24 mm <b>Example:</b> Width of component part = 14 mm</p>	<p><b>Dimension</b> X (X1) = B + 24 mm <b>Exemple:</b> Largeur de la pièce à usiner = 14 mm</p>	<p><b>Mass</b> X2 = B + 33,5 mm <b>Beispiel:</b> Bauteilbreite = 14 mm</p>	<p><b>Dimension</b> X2 = B + 33,5 mm <b>Example:</b> Width of component part = 14 mm</p>	<p><b>Dimension</b> X2 = B + 33,5 mm <b>Exemple:</b> Largeur de la pièce à usiner = 14 mm</p>
<p>Taschenabstand X = 14 + 24 = 38 Das ergibt eine Einlegeluft von 0,8 mm (Hub bis 2,7 mm)</p>	<p>Distance of pocket X = 14 + 24 = 38 This makes a play of 0,8 mm (stroke till 2,7 mm)</p>	<p>Distance de la poche X = 14 + 24 = 38 Ça donne un jeu de 0,8 mm (course jusqu'à 2,7 mm)</p>	<p>Taschenabstand X = 14 + 33,5 = 47,5 Das ergibt eine Einlegeluft von 0,8 mm (Hub bis 2,7 mm)</p>	<p>Distance of pocket X = 14 + 33,5 = 47,5 This makes a play of 0,8 mm (stroke till 2,7 mm)</p>	<p>Distance de la poche X = 14 + 33,5 = 47,5 Ça donne un jeu de 0,8 mm (course jusqu'à 2,7 mm)</p>

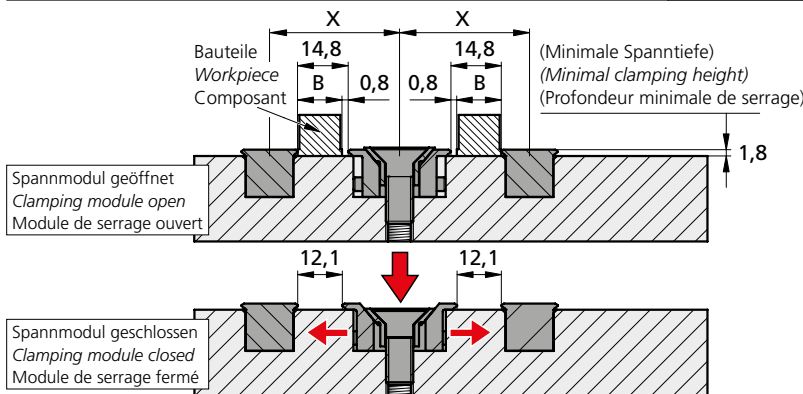

Hub bis / Stroke till / Course jusqu'à = 2,7 mm

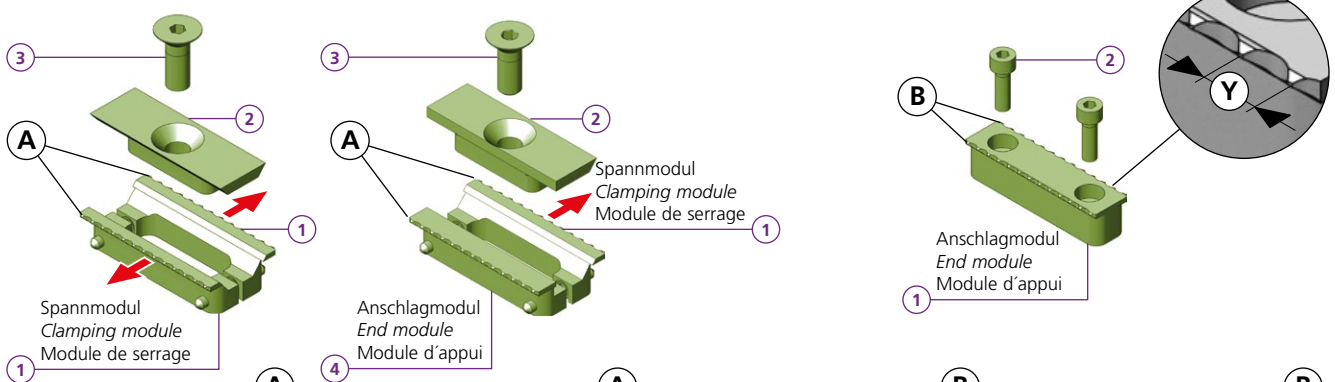
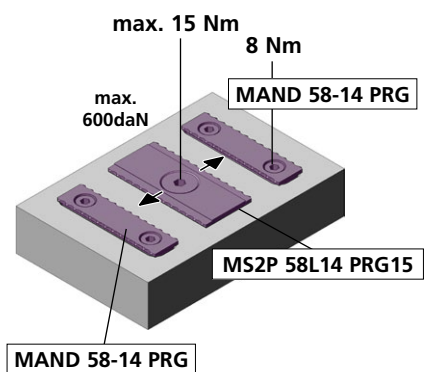

MS2P 58L14 PRG15	
1	2x TK120225
2	1x TK120227
3	1x M8x22 DIN 7991
Y	4,7 mm
kg	~0,12

MS1P 58L14 PRG15	
1	1x TK120225
2	1x TK120721
3	1x M8x22 DIN 7991
4	1x TK120720
Y	4,7 mm
kg	~0,12

MAND 58-14 PRG	
1	1x TK120226
2	2x M5X16 ISO 4762
Y	4,7 mm
kg	~0,08

MAND 58-14 PRG6	
1	1x TB150282
2	2x M5X16 ISO 4762
Y	6,0 mm
kg	~0,08



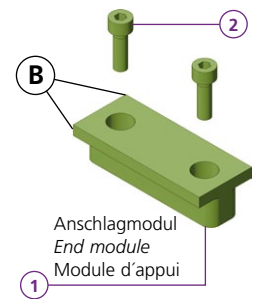
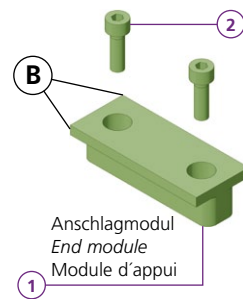
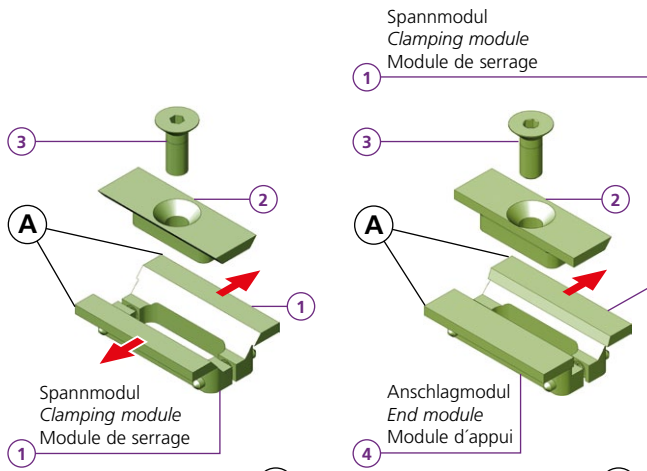

**MS2F 58L14 W251**

- 1 2x TK120531
- 2 1x TK120227
- 3 1x M8x22 DIN 7991

kg ~0,12

**MS1F 58L14 W251**

- 1 1x TK120531
- 2 1x TK120227
- 3 1x M8x22 DIN 7991
- 4 1x TH130566

kg ~0,12

**MANF 58-14 W25**

- 1 1x \*TK120529
- 2 2x M5X16 ISO 4762

kg ~0,11

**MANF 58-14 F25**

- 1 1x TK150033
- 2 2x M5X16 ISO 4762

HV700  
x0,2mm

kg ~0,11

Fertigungsmass für die Vorrichtungplatte / Machining data for the fixture plate / Cotes d'usinage pour la plaque de base: p. 136

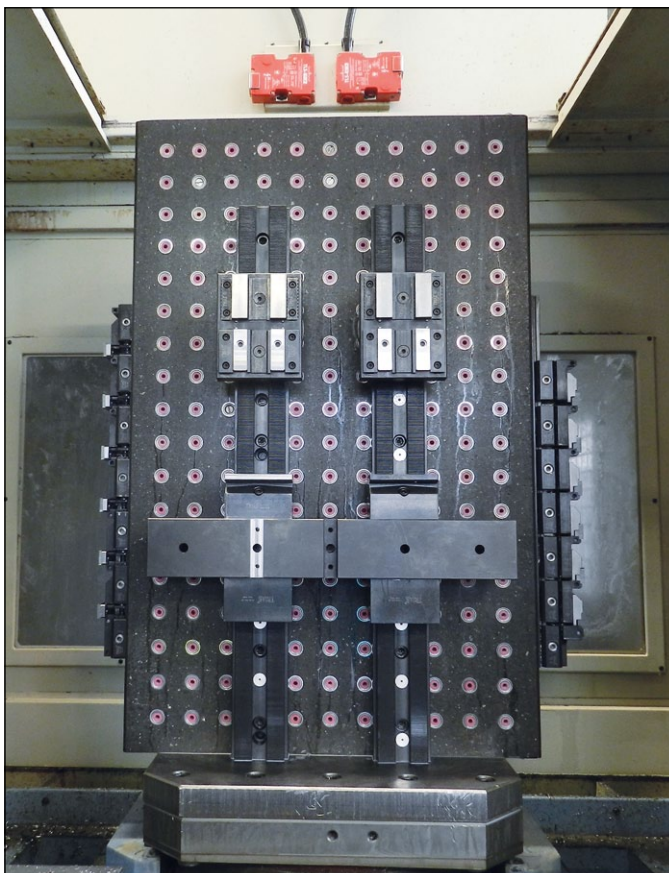

Fertigungsmass für die Vorrichtungplatte:  
Machining data for the fixture plate:  
Cotes d'usinage pour la plaque de base:

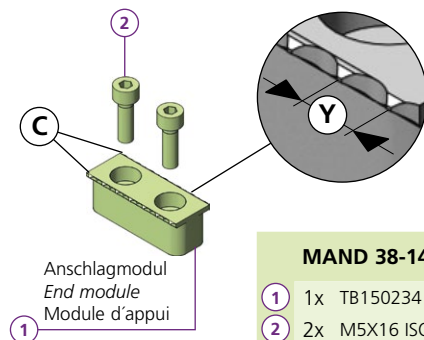
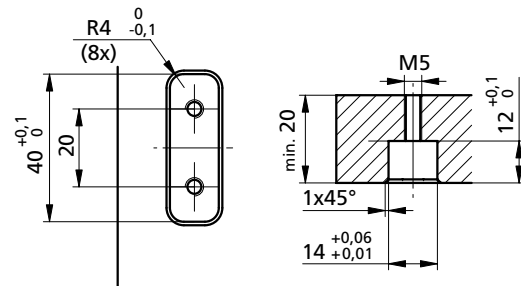

**MAND 38-14 PRG**

- 1 1x TB150234
- 2 2x M5X16 ISO 4762

Y 4,7 mm

kg ~0,08

**MANF 38-14 F25**

- 1 1x TK160533
- 2 2x M5X16 ISO 4762

kg ~0,08

**MANF 38-14 W25**

- 1 1x \*TK160544
- 2 2x M5X16 ISO 4762

kg ~0,08

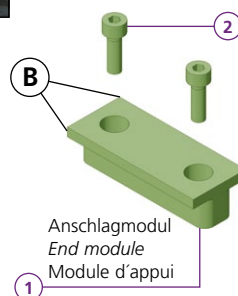

**MAND 38-14 PRG6**

- 1 1x TB150283
- 2 2x M5X16 ISO 4762

Y 6,0 mm

kg ~0,08

\* = weich / soft / doux



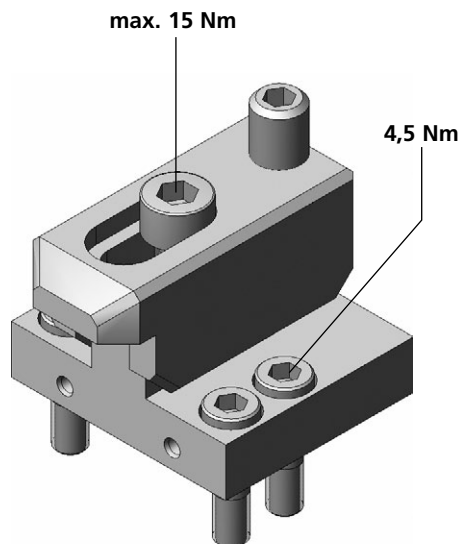
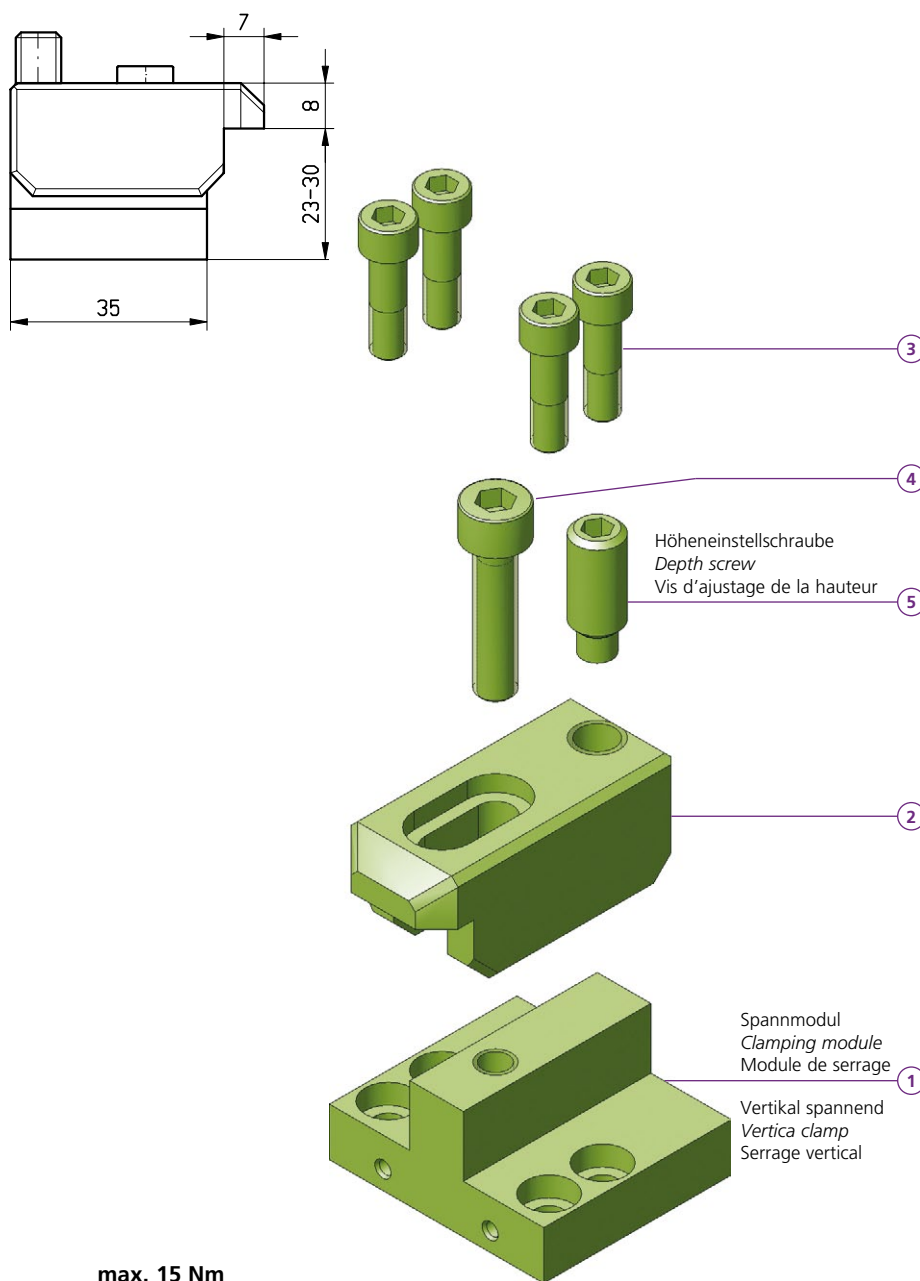
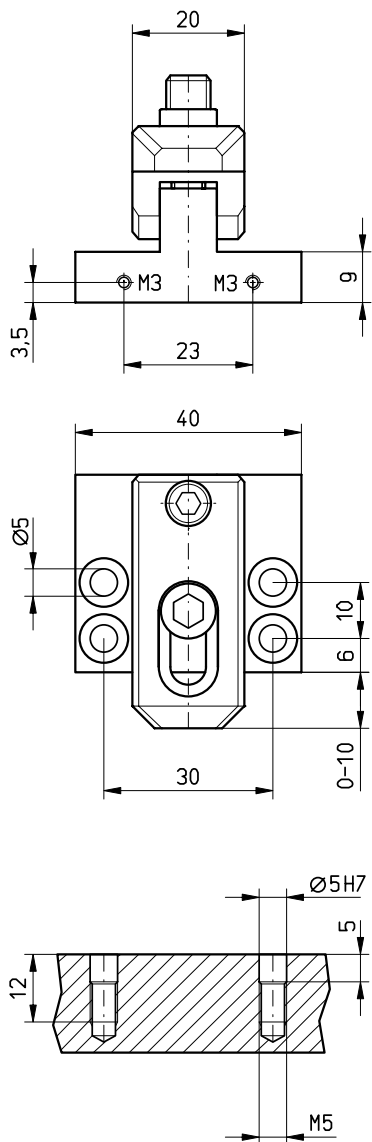

MV1F 20L35 BV1	
1	1x TF140710
2	1x BV1
3	4x MS 50
4	1x M6x25 ISO 4762
5	1x M8x20 ISO 4028
kg	~0,225





# MR1F 30N23 -07

microCLAMP

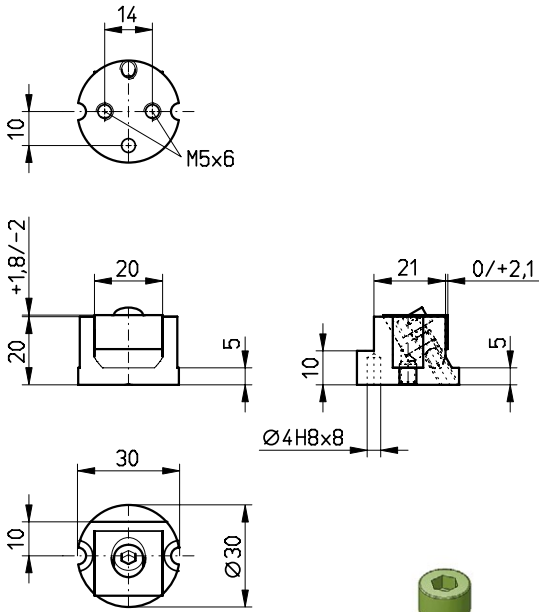

Version 2

Version 1

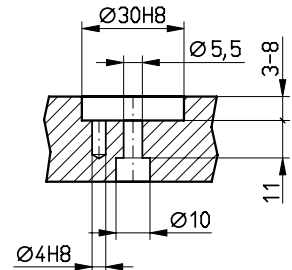
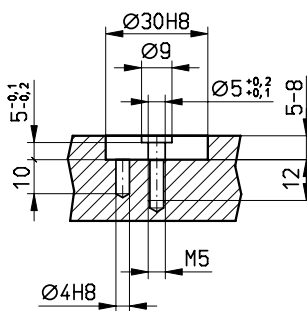
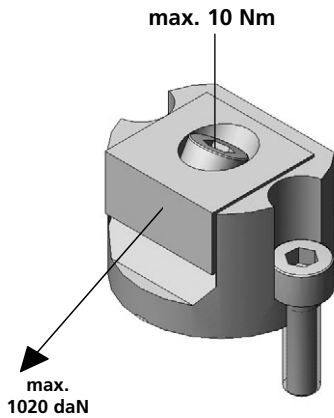
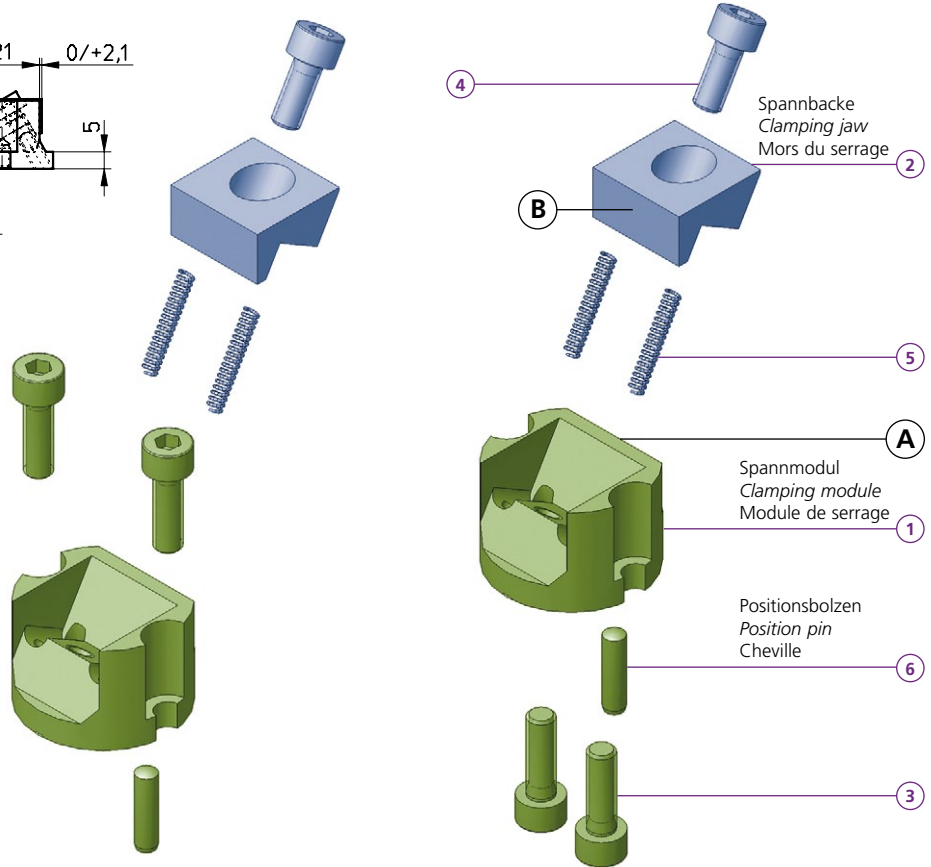

MR1F 30N23 -07	
1	1x TF140711
2	1x
3	2x M5x16 ISO 4762
4	1x M5x12 ISO 4762
5	2x FED 03018
6	1x Ø 4x14 DIN 6325
kg	~0,095

Bestellbeispiel / Ordering example / Exemple de commande:  
1x MR1F 30N23 & 1x B07

	B07	B08	B09
C	20	20	20
H	10	10	10
L	9,5	9,5	9,5
D	5,5	5,5	5,5
e	6	6	6
i	HV700 x0,2mm	HV700 x0,2mm	*

B07, B08, B09

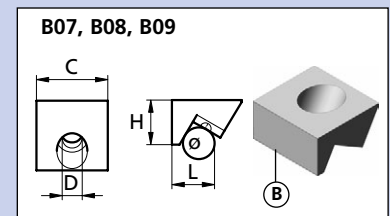

\* = weich / soft / doux



# MS1F 22N40 -07

# microCLAMP

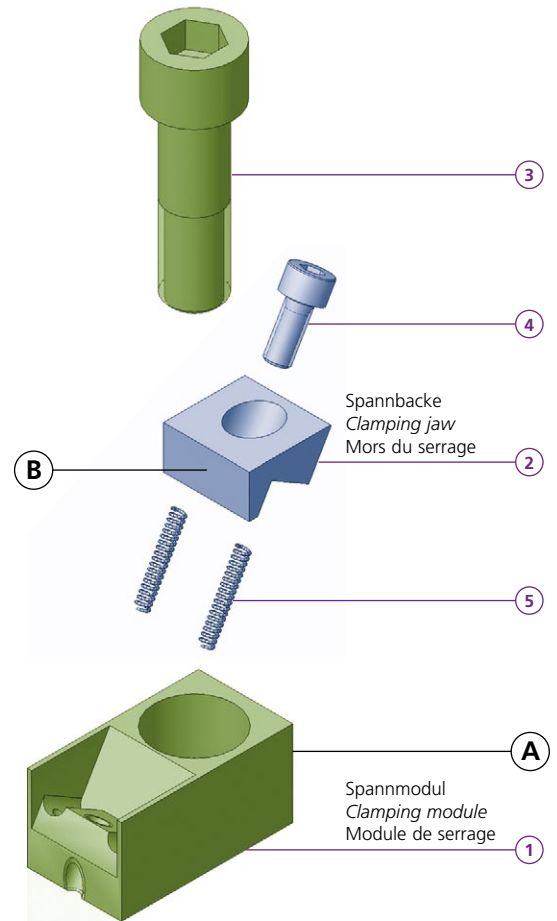
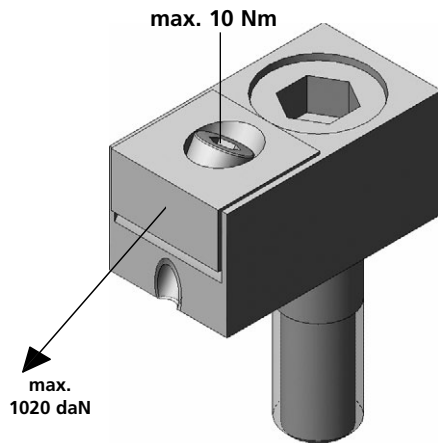
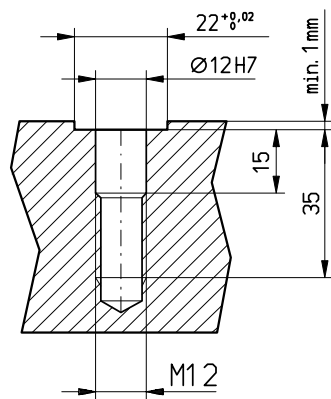
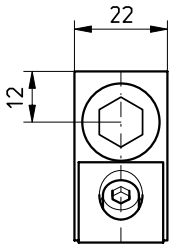
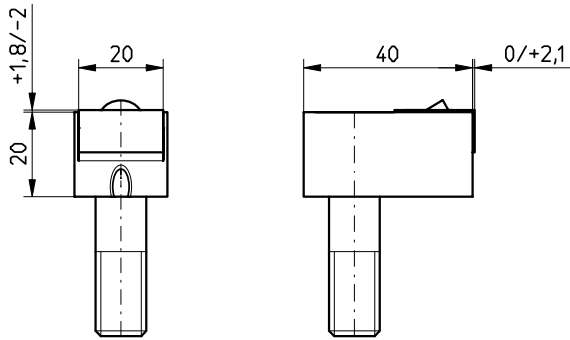

MS1F 22N40 -07	
1	1x TF140712
2	1x _____
3	1x TWPAS 1240
4	1x M5x12 ISO 4762
5	2x FED 03018
kg	~0,15

Bestellbeispiel / Ordering example / Exemple de commande:  
1x MS1F 22N40 & 1x B07

	B07	B08	B09
C	20	20	20
H	10	10	10
L	9,5	9,5	9,5
D	5,5	5,5	5,5
e	6	6	6
i	HV700 x0,2mm	HV700 x0,2mm	*

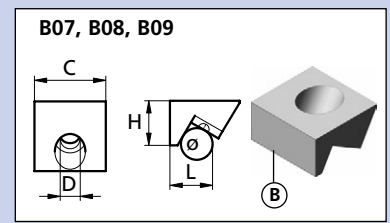

Separat bestellen / Separate order / Commander séparément





# MS1R/F 24N22 -07

microCLAMP

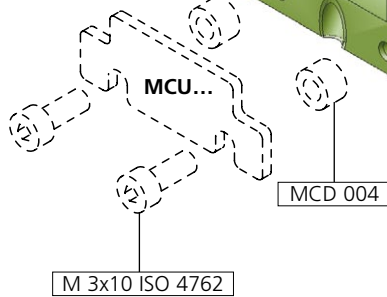
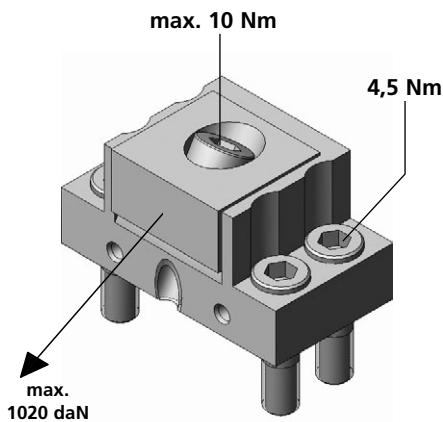
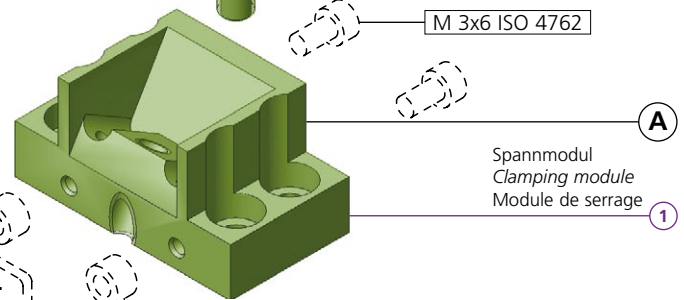
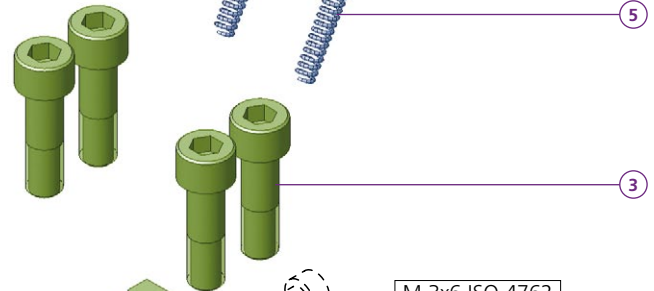
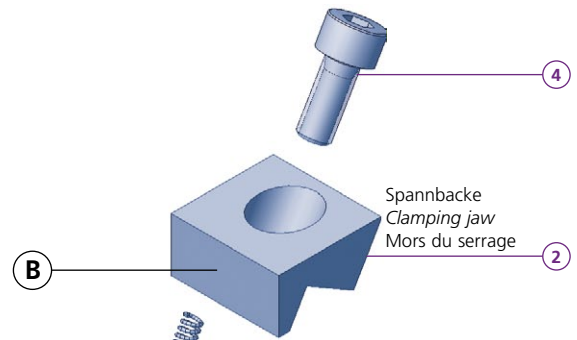
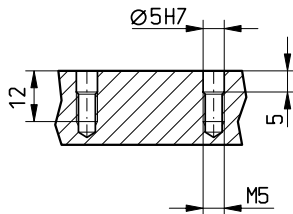
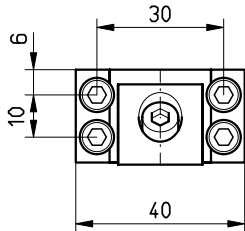
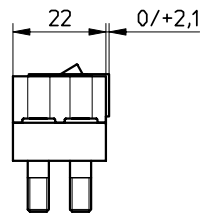
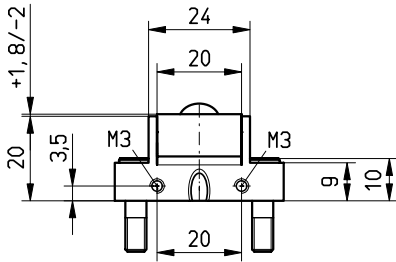

		H	B	N
MCU	11037	11	23	2
	15037	15	23	2
	18037	18	23	2
	20037	20	23	2
	22537	22,5	23	2
2x	M3x10 ISO 4262			
2x	M3x6 ISO 4262			
2x	MCD 004			

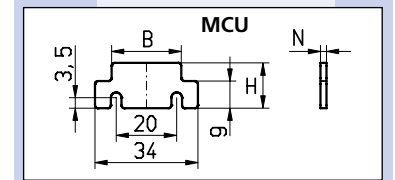

**Achtung:** Bei Spannkraften über 400 daN (0,4t) sollte das Spannmodul in eine Nut eingelassen werden (Nuttiefe mindestens 1mm)  
**Remark:** Using forces higher than 400 daN, clamps must be mounted into a slot (depth min. 1mm)  
**Attention:** Avec des forces de serrage en dessus de 400 daN, le module de serrage doit être encastré dans une rainure de 1mm de profondeur minimum

MS1F 24N22 -07	
1	1x TF140713
MS1R 24N22 -07	
1	1x TW100172-01
2	1x
3	4x MS 50
4	1x M5x12 ISO 4762
5	2x FED 03018
kg	~0,125

**Bestellbeispiel / Ordering example / Exemple de commande:**  
 1x MS1F 24N22 & 1x B07

	B07	B08	B09
C	20	20	20
H	10	10	10
L	9,5	9,5	9,5
D	5,5	5,5	5,5
e	6	6	6
i	HV700 x0,2mm	HV700 x0,2mm	*

\* = weich / soft / doux

Separat bestellen / Separate order / Commander séparément



# MS1R/F 25N25 -13

microCLAMP

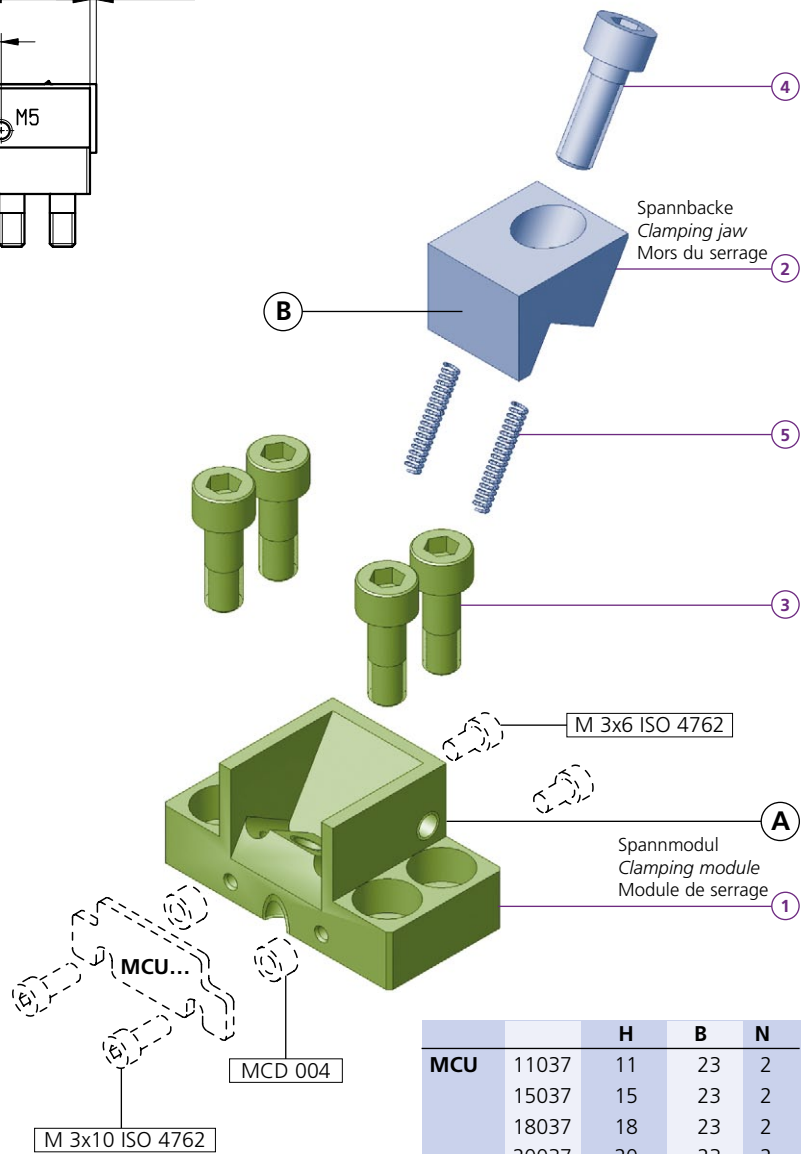
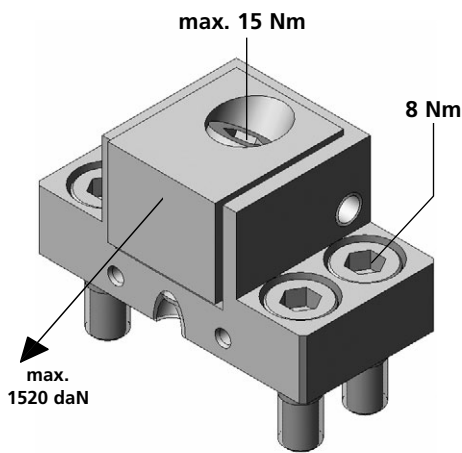
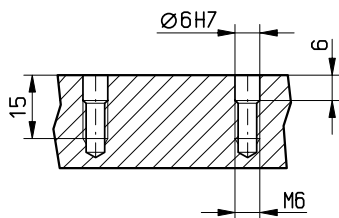
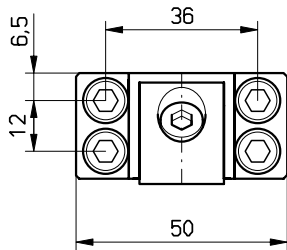
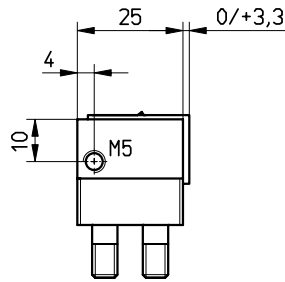
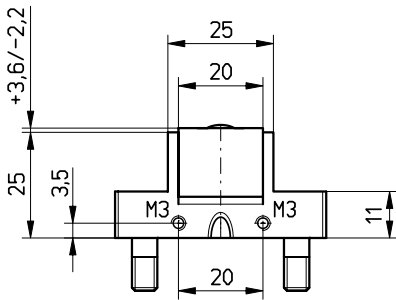

		H	B	N
<b>MCU</b>	11037	11	23	2
	15037	15	23	2
	18037	18	23	2
	20037	20	23	2
	22537	22,5	23	2
2x	M3x10 ISO 4262			
2x	M3x6 ISO 4262			
2x	MCD 004			

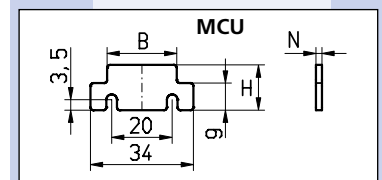

**Achtung:** Bei Spannkraften über 400 daN (0,4t) sollte das Spannmodul in eine Nut eingelassen werden (Nuttiefe mindestens 1mm)

**Remark:** Using forces higher than 400 daN, clamps must be mounted into a slot (depth min. 1mm)

**Attention:** Avec des forces de serrage en dessus de 400 daN, le module de serrage doit être encastré dans une rainure de 1mm de profondeur minimum

Bestellbeispiel / Ordering example / Exemple de commande:

1x MS1F 25N25 & 1x B13

MS1F 25N25 -13	
①	1x TF140714
MS1R 25N25 -13	
①	1x TF140715
②	1x
③	4x MS 60
④	1x M6x16 ISO 4762
⑤	2x FED 03018
kg	~0,165

	B13	B14	B15	B16
③	20	20	20	20
④	16	16	16	16
⑤	13,8	13,8	13,8	19
⑥	6,5	6,5	6,5	6,5
⑦	10	10	10	10
⑧	HV700 x0,2mm	HV700 x0,2mm	*	*

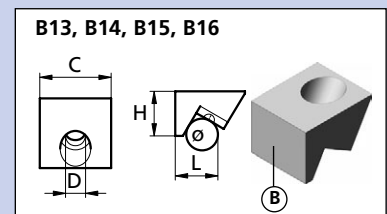





MS1R/F 35L14 -150

Linear

microCLAMP

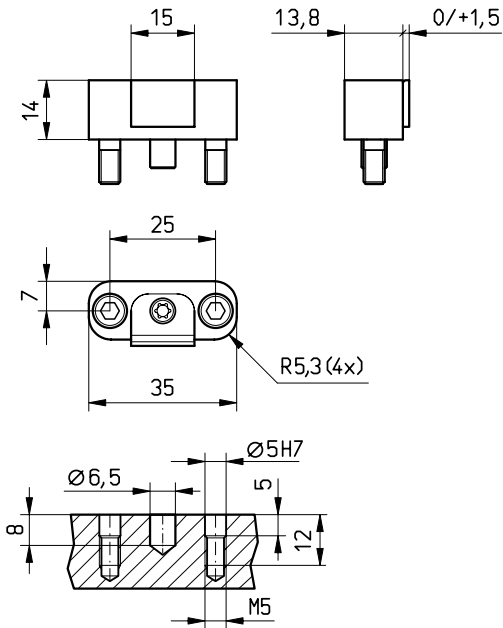

Drehmoment Torque Couple de torsion	Spannkraft Workholding force Force de serrage
7 Nm	lb-ft 5,18 = 0,39 t 390 daN
8 Nm	lb-ft 5,92 = 0,45 t 450 daN
9 Nm	lb-ft 6,66 = 0,51 t 510 daN
10 Nm	lb-ft 7,4 = 0,57 t 570 daN

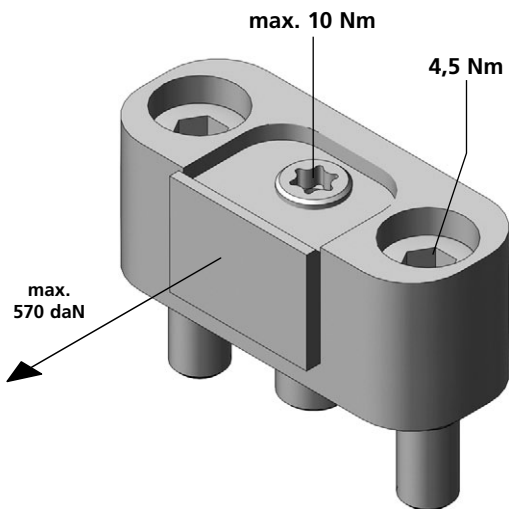
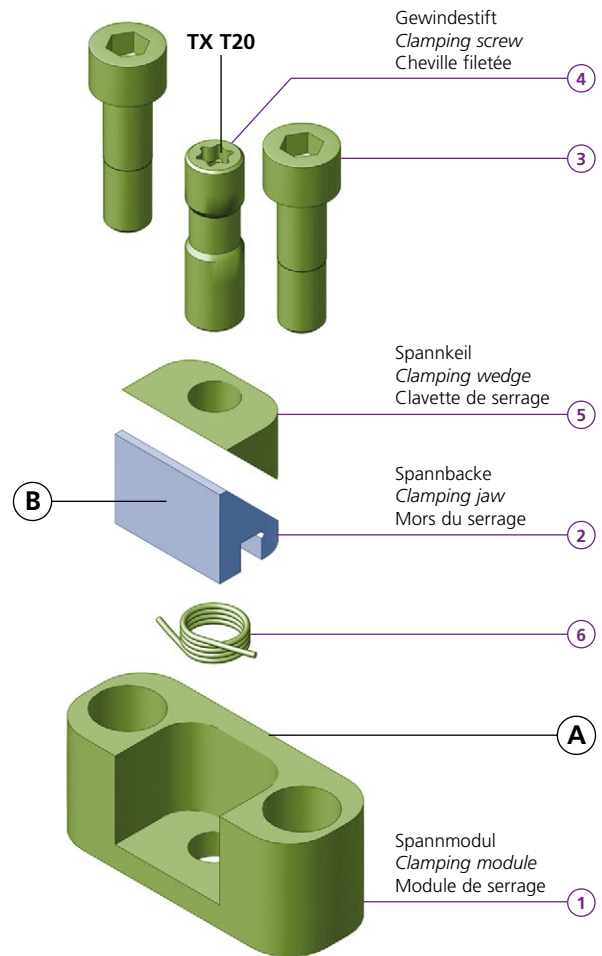

Montageanleitung / Mounting instruction / Notice de montage

Positionieren des Gewindestiftes vor Aufsetzen des Spannknebels

Before mounting the wedge the clamping screw must be positioned

Positionner la cheville filetée avant de mettre la clavette de serrage

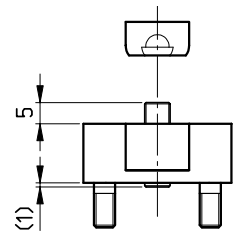

**Achtung:** Bei Spannkraften über 400 daN (0,4t) sollte das Spannmodul in eine Nut eingelassen werden (Nuttiefe mindestens 1mm)  
**Remark:** Using forces higher than 400 daN, clamps must be mounted into a slot (depth min. 1mm)  
**Attention:** Avec des forces de serrage en dessus de 400 daN, le module de serrage doit être encastré dans une rainure de 1mm de profondeur minimum

Bestellbeispiel / Ordering example / Exemple de commande:

1x MS1F 35L14 & 1x B150

<b>MS1F 35L14 -150</b>	
1x TF140716	
<b>MS1R 35L14 -150</b>	
1x TF140717	
1x _____	
2x MS 50	
1x GEWST6L20	
1x MSK15W45	
1x SFED6W90	
kg ~0,03	

	B150	B151	B152
<b>C</b>	15	15	15
<b>H</b>	11	11	11
<b>L</b>	40,3	40,3	40,3
<b>ø</b>	40	40	40
<b>i</b>	HV700 x0,2mm	HV700 x0,2mm	ALU

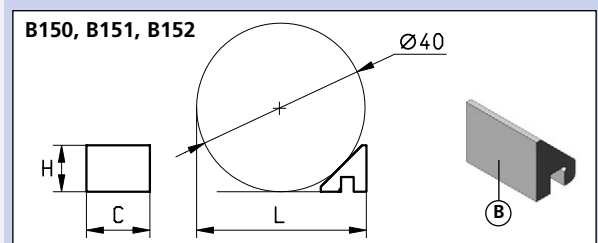



# MS1F 35N14 -01

# MS1F 35N22 -01

microCLAMP

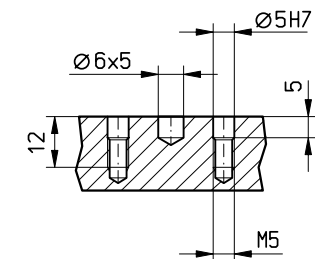
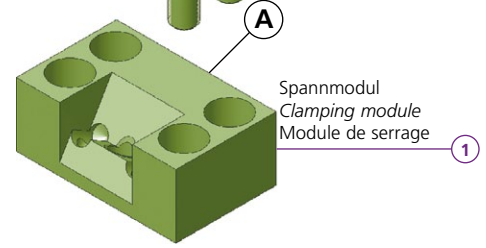
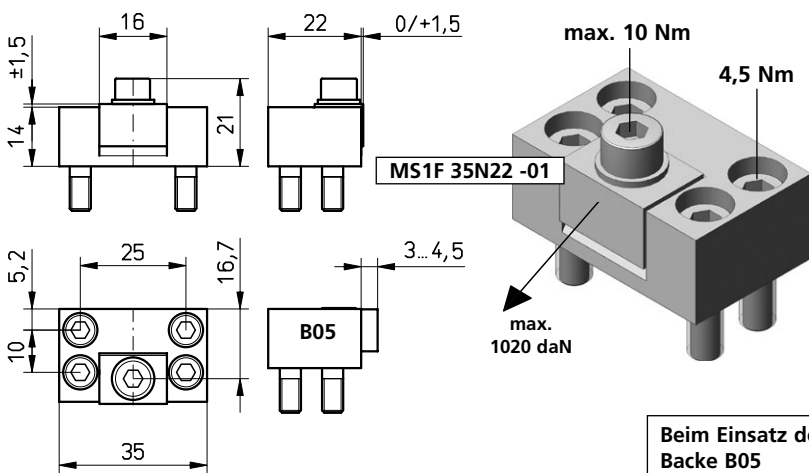
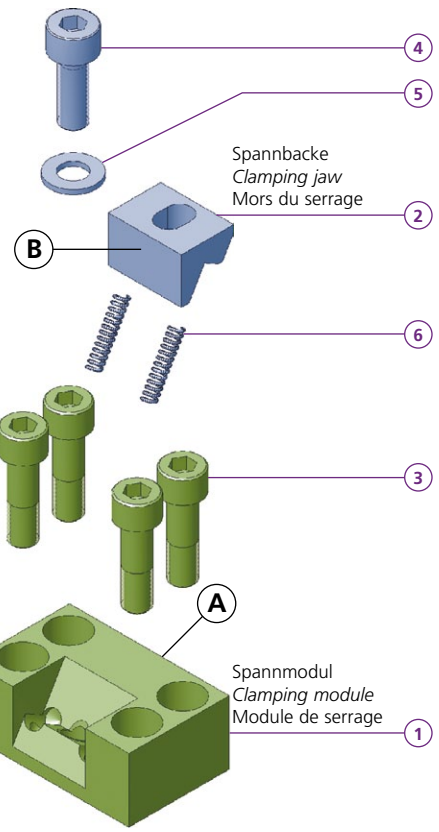
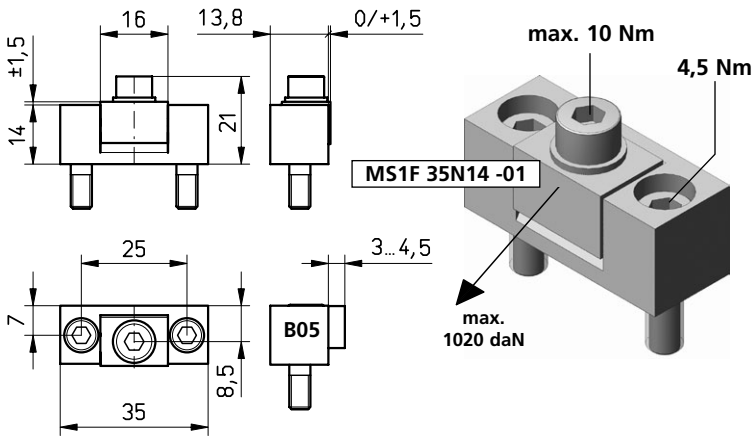

**Beim Einsatz der Backe B05** / **Jaw B05 in use** / **Pour l'utilisation du mors B05**

*If a stroke of 1,1 to 1,5mm is required the module must be machined according to this sketch.*

*Travail de reprise au module si la course du mors totale (1,1 jusqu'à 1,5mm) est exigée.*

**Achtung:** Bei Spannkraften über 400 daN (0,4t) sollte das Spannmodul in eine Nut eingelassen werden (Nuttiefe mindestens 1mm)

**Remark:** Using forces higher than 400 daN, clamps must be mounted into a slot (depth min. 1mm)

**Attention:** Avec des forces de serrage en dessus de 400 daN, le module de serrage doit être encastré dans une rainure de 1mm de profondeur minimum

MS1F 35N14 -01	
1	1x TF140718
2	1x
3	2x MS 50
4	1x M5x14 ISO 4762
5	1x 5x10x1 DIN 125 A
6	2x FED 02813
kg	~0,05

MS1F 35N22 -01	
1	1x TF140719
3	4x MS 50
kg	~0,08

**Bestellbeispiel / Ordering example / Exemple de commande:**  
1x MS1F 35N14 & 1x B01

	B01	B02	B03	B04	B05	B05 R
C	16	16	16	16	16	16
H	10	10	10	10	10	10
L	8	8	11	8	10	10
D	5,5	5,5	5,5	5,5	5,2	5,2
e	4	4	4	4	4	4
i	HV700 x0,2mm	HV700 x0,2mm	*	Messing Brass Laiton	HV700 x0,2mm	HV700 x0,2mm

Separat bestellen / Separate order / Commander séparément





# MS2X 35N23 -01

microCLAMP

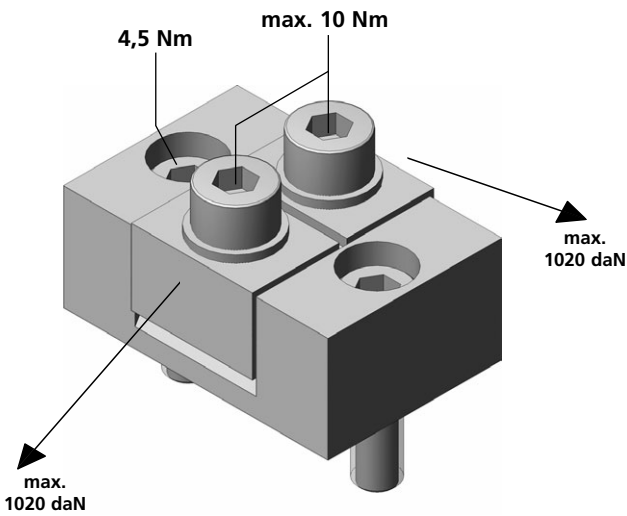
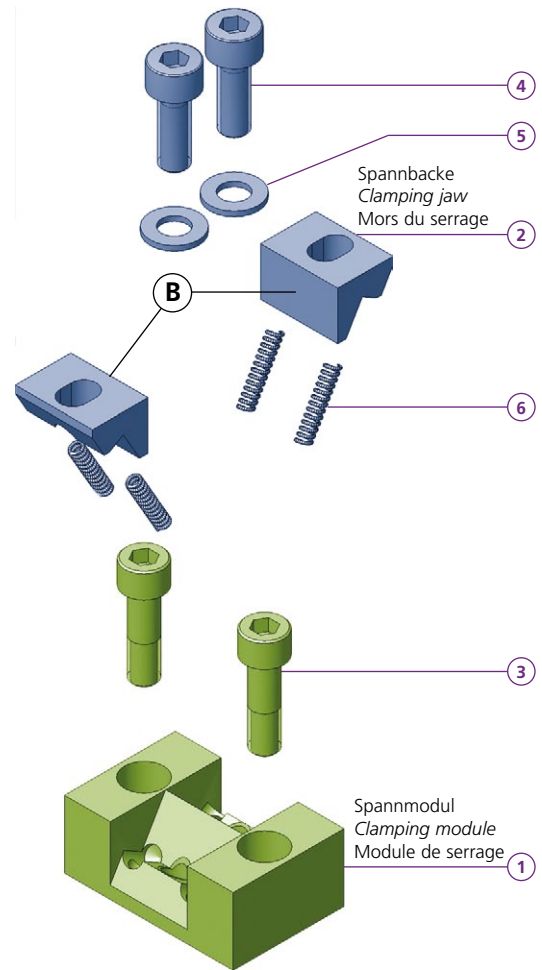
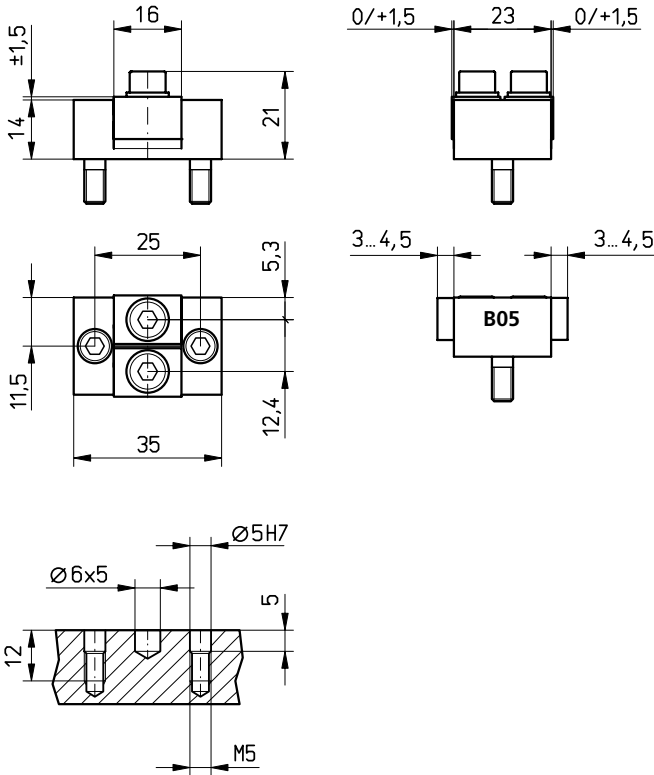

Beim Einsatz der Backe B05	Jaw B05 in use	Pour l'utilisation du mors B05
Nachbearbeitung am Modul, falls gesamter Backenhub (1,1 bis 1,5mm) verlangt ist.	If a stroke of 1,1 to 1,5mm is required the module must be machined according to this sketch.	Travail de reprise au module si la course du mors totale (1,1 jusqu'à 1,5mm) est exigée.

**Achtung:** Bei Spannkraften über 400 daN (0,4t) sollte das Spannmódul in eine Nut eingelassen werden (Nuttiefe mindestens 1mm)  
**Remark:** Using forces higher than 400 daN, clamps must be mounted into a slot (depth min. 1mm)  
**Attention:** Avec des forces de serrage en dessus de 400 daN, le module de serrage doit être encastré dans une rainure de 1mm de profondeur minimum

Bestellbeispiel / Ordering example / Exemple de commande:  
 1x MS2X 35N23 & 2x B01

MS2X 35N23 -01		B01	B02	B03	B04	B05	B05 R
1	1x TF140720	16	16	16	16	16	16
2	2x	10	10	10	10	10	10
3	2x MS 50	8	8	11	8	10	10
4	2x M5x14 ISO 4762	5,5	5,5	5,5	5,5	5,2	5,2
5	2x 5x10x1 DIN 125 A	4	4	4	4	4	4
6	4x FED 02813	HV700	HV700	*	Messing	HV700	HV700
kg	~0,085	x0,2mm	x0,2mm		Brass	x0,2mm	x0,2mm
					Laiton		

\* = weich / soft / doux



# MS2F 60N14 -01

microCLAMP

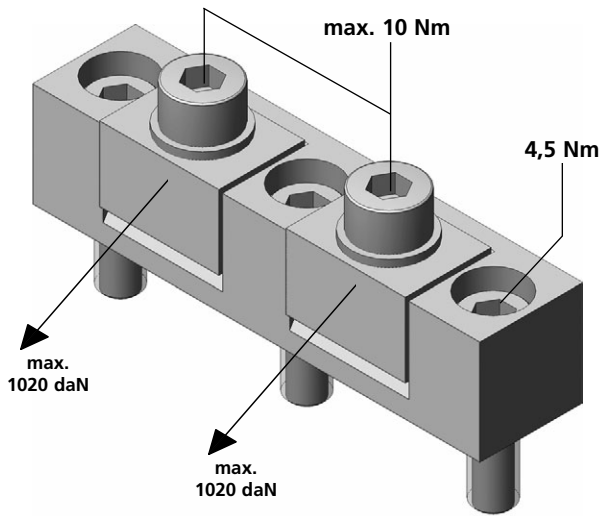
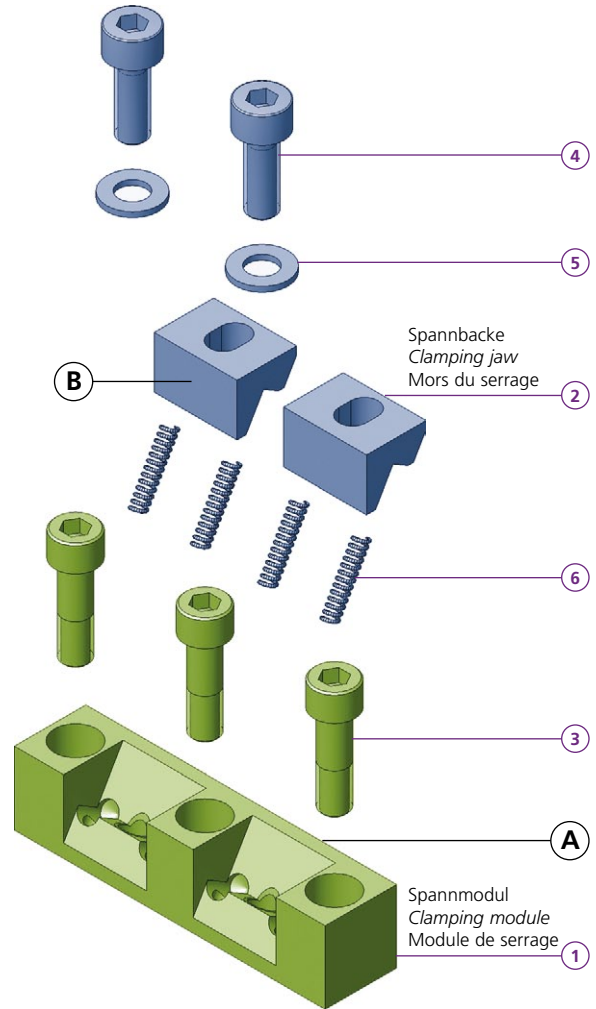
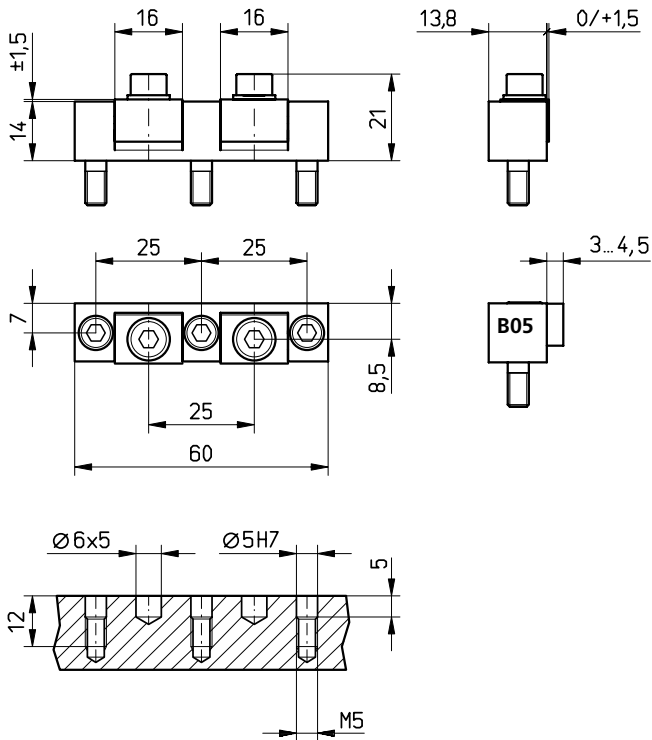

**Beim Einsatz der Backe B05** *Jaw B05 in use* **Pour l'utilisation du mors B05**

Nachbearbeitung am Modul, falls gesamter Backenhub (1,1 bis 1,5mm) verlangt ist. *If a stroke of 1,1 to 1,5mm is required the module must be machined according to this sketch.* Travail de reprise au module si la course du mors totale (1,1 jusqu'à 1,5mm) est exigée.

**Achtung:** Bei Spannkraften über 400 daN (0,4t) sollte das Spannmódul in eine Nut eingelassen werden (Nuttiefe mindestens 1mm)  
**Remark:** Using forces higher than 400 daN, clamps must be mounted into a slot (depth min. 1mm)  
**Attention:** Avec des forces de serrage en dessus de 400 daN, le module de serrage doit être encastré dans une rainure de 1mm de profondeur minimum

Bestellbeispiel / Ordering example / Exemple de commande:  
 1x MS2F 60N14 & 2x B01

MS2F 60N14 -01		B01	B02	B03	B04	B05	B05 R
1	1x TF140721	16	16	16	16	16	16
2	2x	10	10	10	10	10	10
3	3x MS 50	8	8	11	8	10	10
4	2x M5x14 ISO 4762	5,5	5,5	5,5	5,5	5,2	5,2
5	2x 5x10x1 DIN 125 A	4	4	4	4	4	4
6	4x FED 02813	HV700	HV700	*	Messing	HV700	HV700
kg	~0,09	x0,2mm	x0,2mm		Brass	x0,2mm	x0,2mm
					Laiton		

**B01, B02, B03, B04**

**B05**

M5x10 DIN 6912





# MS3F 85N14 -01

microCLAMP

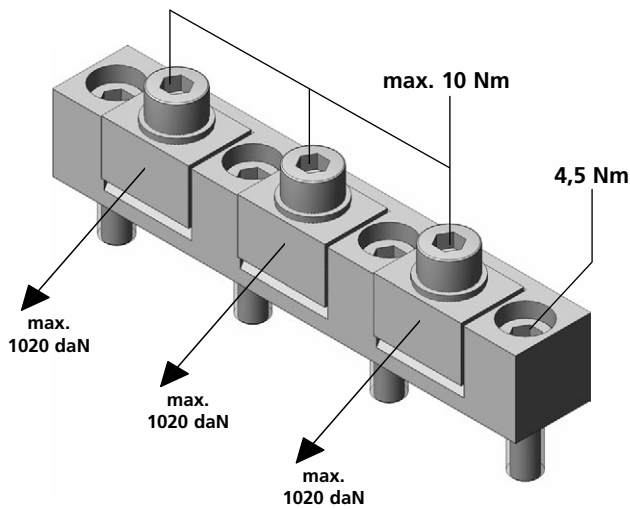
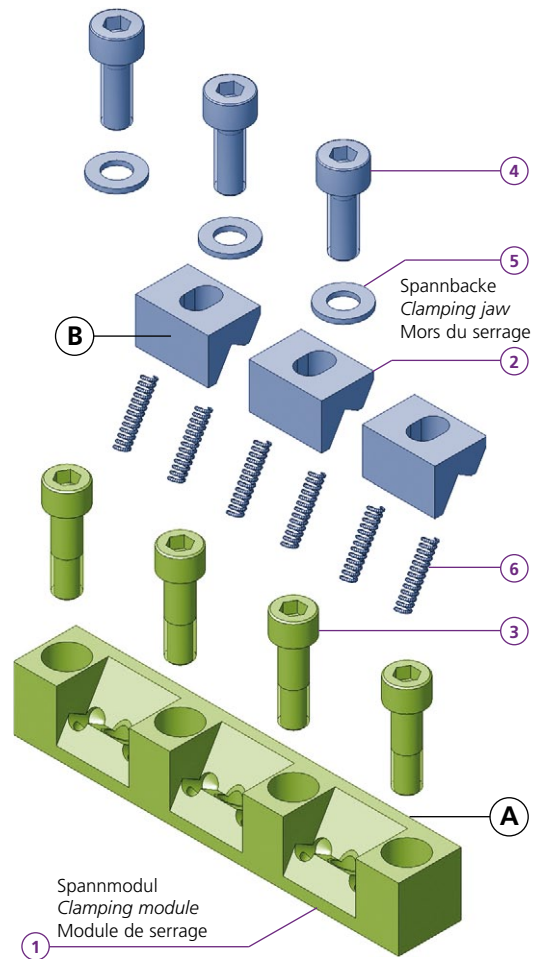
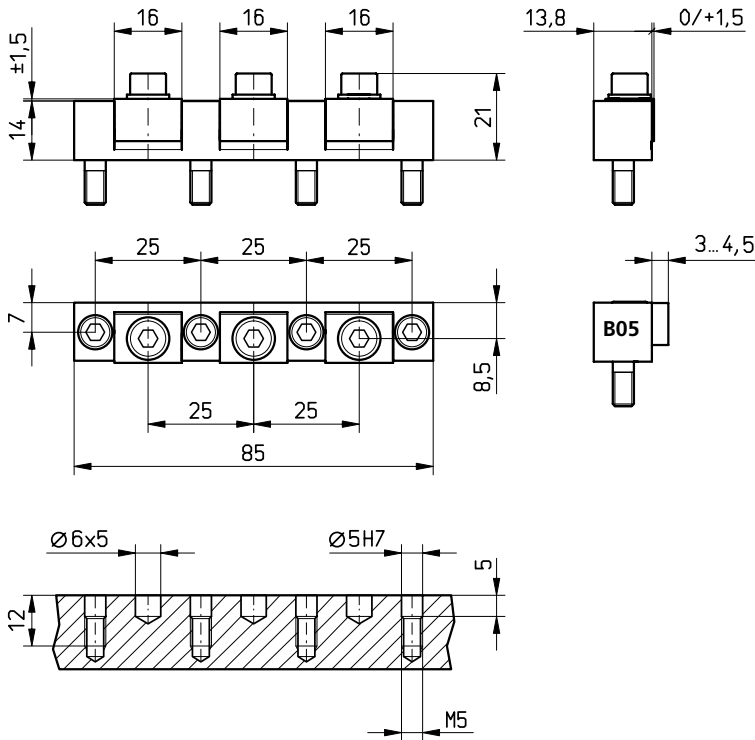

**Beim Einsatz der Backe B05** *Jaw B05 in use* **Pour l'utilisation du mors B05**  
 Nachbearbeitung am Modul, *if a stroke of 1,1 to 1,5mm is required the module* Travail de reprise au module si  
 falls gesamt Backenhub (1,1 *must be machined according to this sketch.* la course du mors totale (1,1  
 bis 1,5mm) verlangt ist.

**Achtung:** Bei Spannkraften über 400 daN (0,4t) sollte das Spanndeckel in eine Nut eingelassen werden (Nuttiefe mindestens 1mm)  
**Remark:** Using forces higher than 400 daN, clamps must be mounted into a slot (depth min. 1mm)  
**Attention:** Avec des forces de serrage en dessus de 400 daN, le module de serrage doit être encastré dans une rainure de 1mm de profondeur minimum

Bestellbeispiel / Ordering example / Exemple de commande:  
 1x MS3F 85N14 & 3x B01

MS3F 85N14 -01		B01	B02	B03	B04	B05	B05 R
1	1x TF140722	16	16	16	16	16	16
2	3x	10	10	10	10	10	10
3	4x MS 50	8	8	11	8	10	10
4	3x M5x14 ISO 4762	5,5	5,5	5,5	5,5	5,2	5,2
5	3x 5x10x1 DIN 125 A	4	4	4	4	4	4
6	6x FED 02813	HV700 x0,2mm	HV700 x0,2mm	*	Messing Brass Laiton	HV700 x0,2mm	HV700 x0,2mm
kg	~0,125						

\* = weich / soft / doux

Separat bestellen / Separate order / Commander séparément



# VS1R/F 19N35 -20

microCLAMP

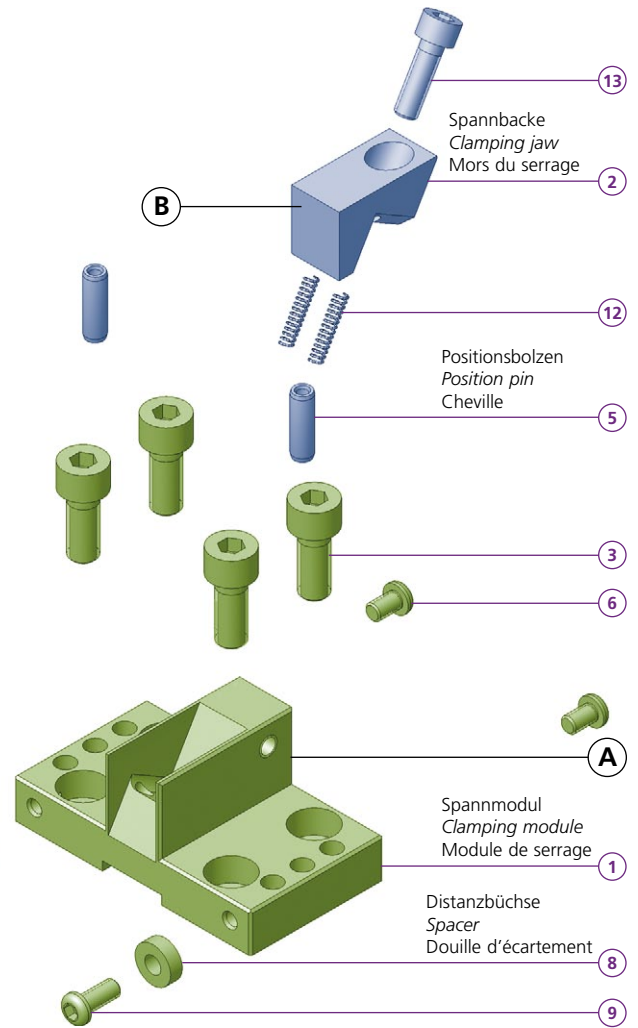
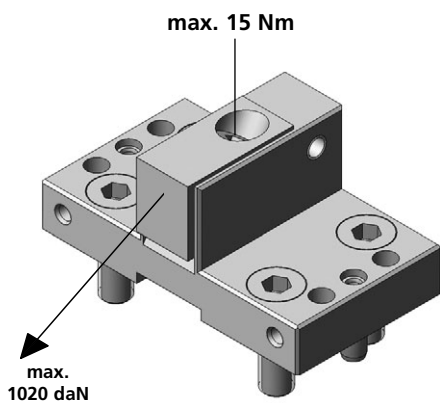
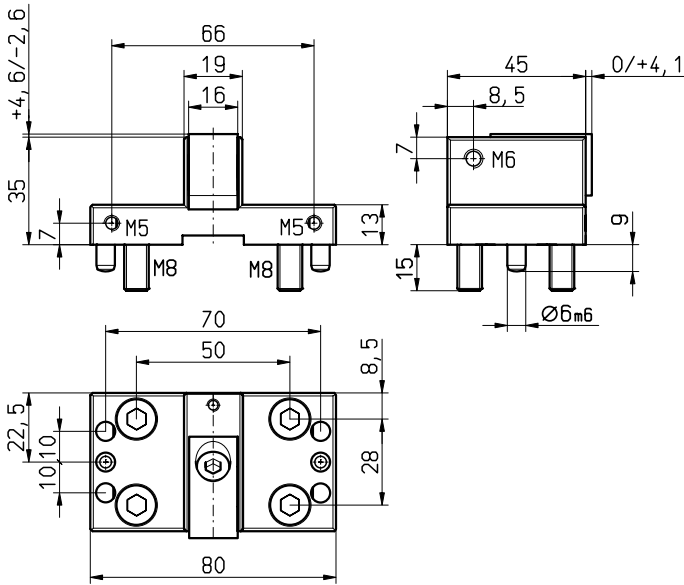

<b>VS1F 19N35 -20</b>	<b>A</b>
1x TF150029	
<b>VS1R 19N35 -20</b>	
1x TF140723	
1x	
4x M8x20 ISO 4762	
2x CCBO 0802	
2x M5x8 ISO 7380	
2x CCD 004	
2x M5x12 ISO 7380	
2x FED 0418	
1x M6x20 ISO 4762	
kg ~0,505	

<b>B</b>			
	<b>B20</b>	<b>B21</b>	<b>B22</b>
<b>C</b>	16	16	16
<b>H</b>	20	20	20
<b>L</b>	19	19	19
<b>D</b>	6,5	6,5	6,5
<b>e</b>	12	12	12
<b>i</b>	HV700 x0,2mm	HV700 x0,2mm	*

Bestellbeispiel / Ordering example / Exemple de commande:  
1x VS1R 19N35 & 1x B20

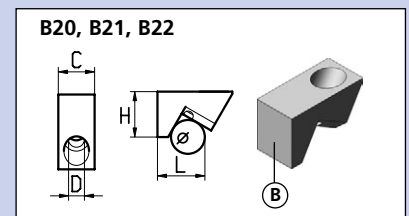





# VS1R 26L35 -31

# Linear

# microCLAMP

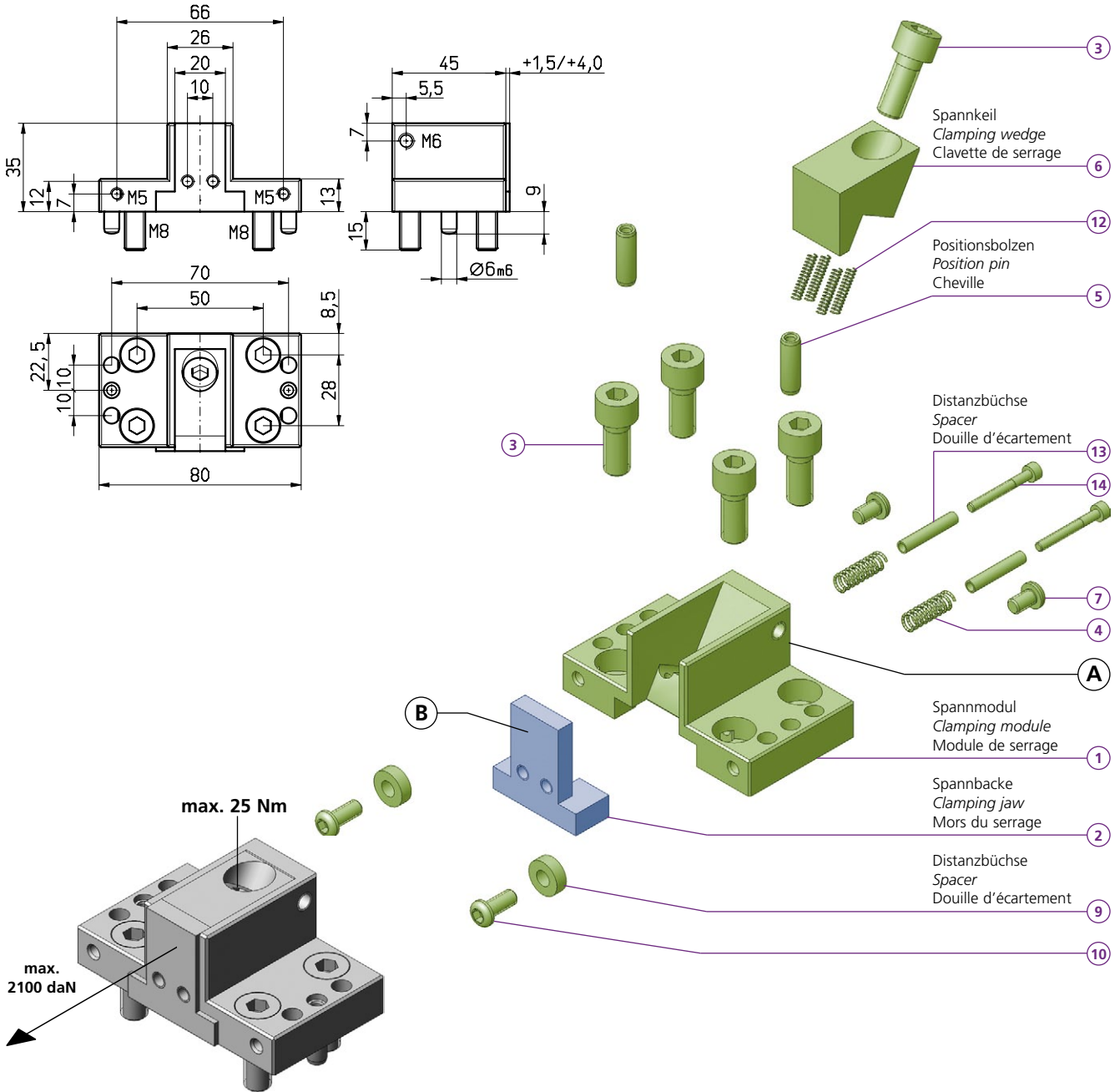

VS1R 26L35 -31	
1	1x TF140724
2	1x
3	5x M8x20 ISO 4762
4	2x FED 0618
5	2x CCBO 0802
6	1x B30
7	2x M5x8 ISO 7380
9	2x CCD 004
10	2x M5x12 ISO 7380
12	4x FED 0418
13	2x CCD 422
14	2x M3x25 ISO 4762
kg	~0,55

	B31	B32	B33
C	20	20	20
H	35	35	35
L	6	6	6
D	-	-	-
e	-	-	-
i	HV700 x0,2mm	HV700 x0,2mm	*

Bestellbeispiel / Ordering example / Exemple de commande:  
1x VS1R 26L35 & 1x B31

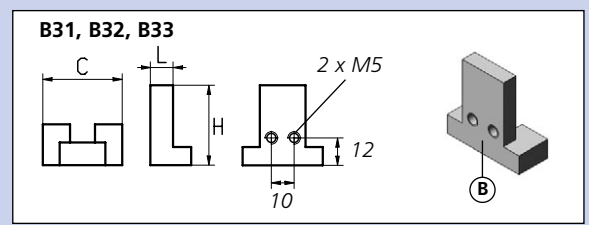

Separat bestellen / Separate order / Commander séparément



# VS1R 26N35 -26

microCLAMP

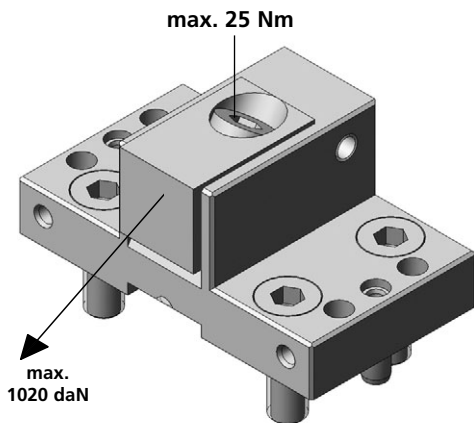
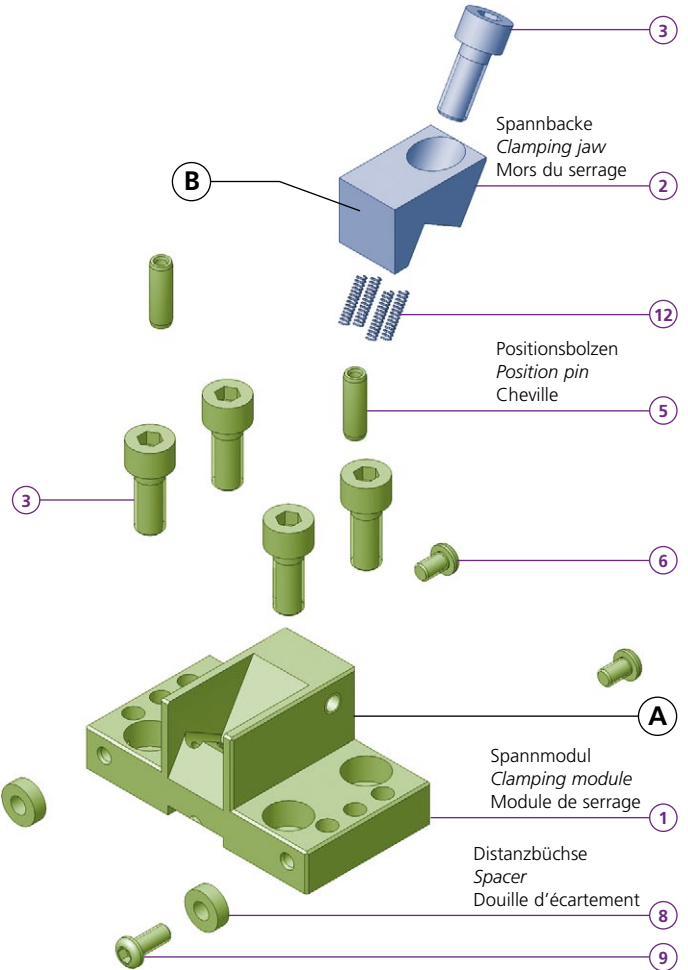
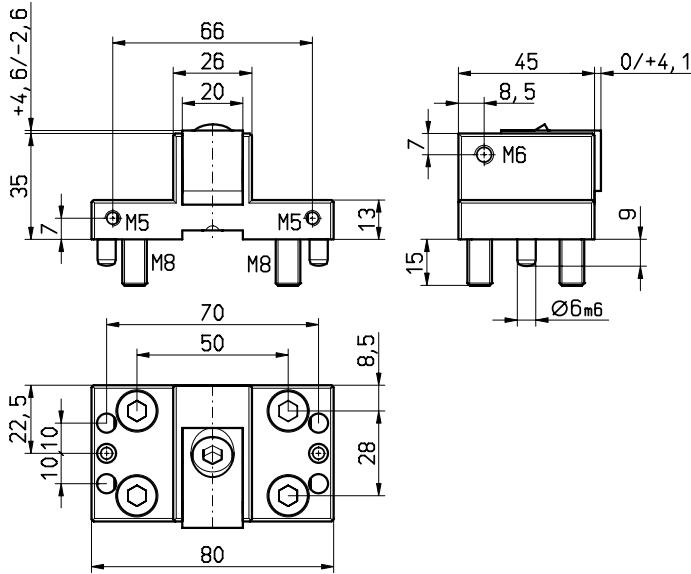

VS1R 26N35 -26	
1	1x TF140725
2	1x
3	5x M8x20 ISO 4762
5	2x CCBO 0802
6	2x M5x8 ISO 7380
8	2x CCD 004
9	2x M5x12 ISO 7380
12	4x FED 0418
kg	~0,55

	B26	B27	B28
C	20	20	20
H	20	20	20
L	19	19	19
D	9	9	9
e	12	12	12
i	HV700 x0,2mm	HV700 x0,2mm	*

Bestellbeispiel / Ordering example / Exemple de commande:  
1x VS1R 26N35 & 1x B26

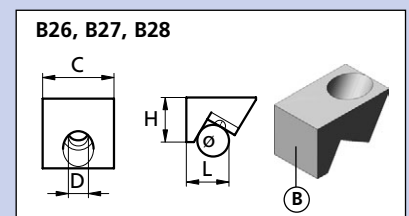





# VS1R 38N50 -60

# microCLAMP

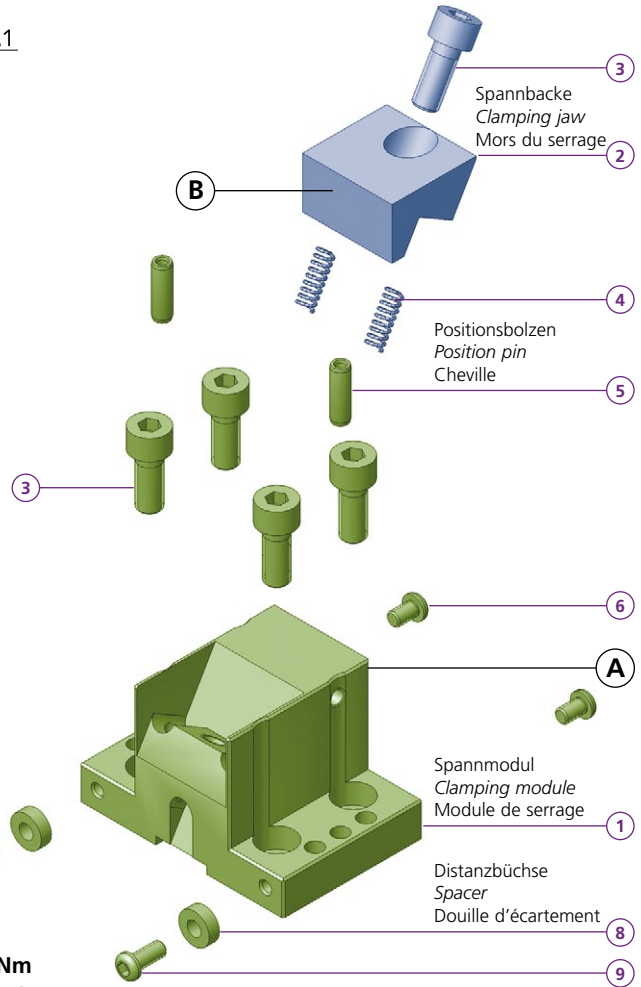
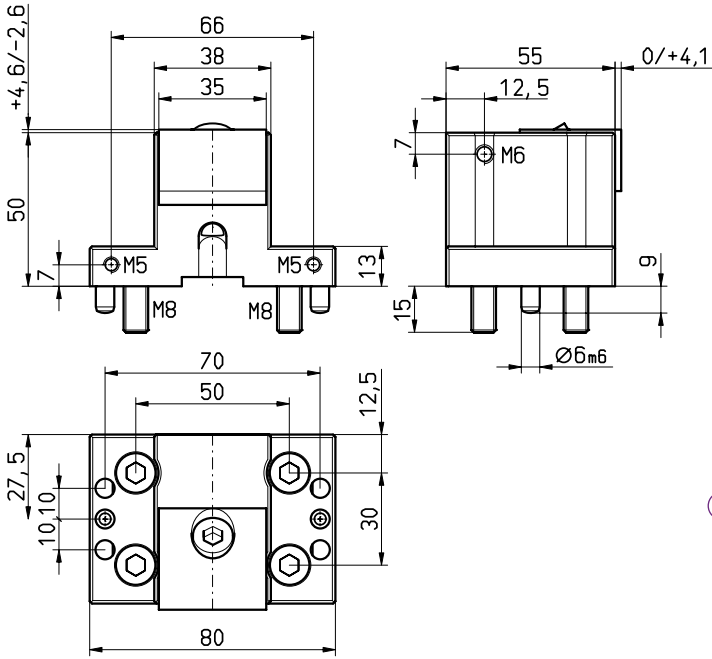

**VS1R 38N50 -60**

1	1x	TF140726
2	1x	
3	5x	M8x20 ISO 4762
4	2x	FED 0618
5	2x	CCBO 0802
6	2x	M5x8 ISO 7380
8	2x	CCD 004
9	2x	M5x12 ISO 7380
kg		~1,01

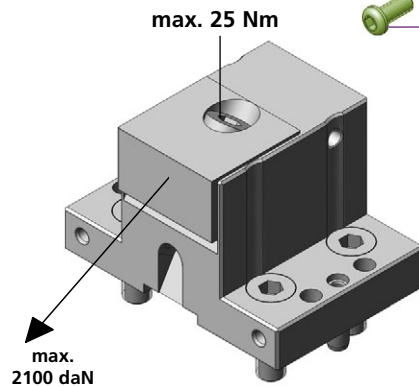

### Bestellbeispiel / Ordering example / Exemple de commande:

1x VS1R 38N50 & 1x B60

	B58	B60	B61	B62	B62HM	B65	B66	B67	B68	B69	B77	B79	B79R
C	35	35	35	35	35	35	35	35	35	35	35	35	35
H	20	20	20	20	20	20	20	20	20	20	20	20	20
L	24	19	19	19	19	19	19	24	26	22	22	25	25
D	9	9	9	9	9	9	9	9	9	9	9	9	9
o	12	12	12	12	12	12	12	12	12	12	12	12	12
i	ALU *	56 HRC	56 HRC	*	HM	HV700 x0,2mm	HV700 x0,2mm	HV700 x0,2mm	*	*	56 HRC	HV700 x0,2mm	HV700 x0,2mm

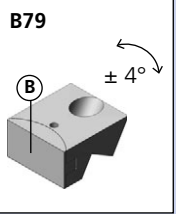
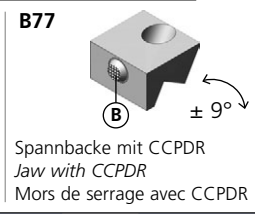
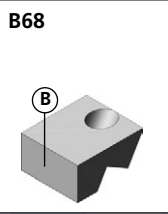
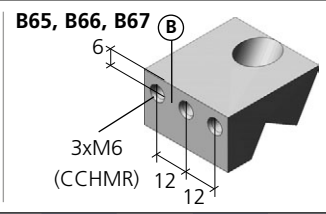
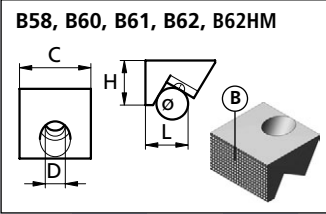
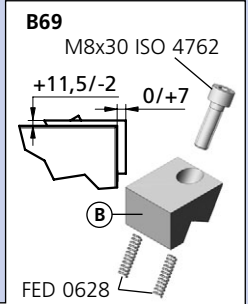

\* = weich / soft / doux

Separat bestellen / Separate order / Commander séparément



VS1R/F 41L30 -51

Linear

microCLAMP

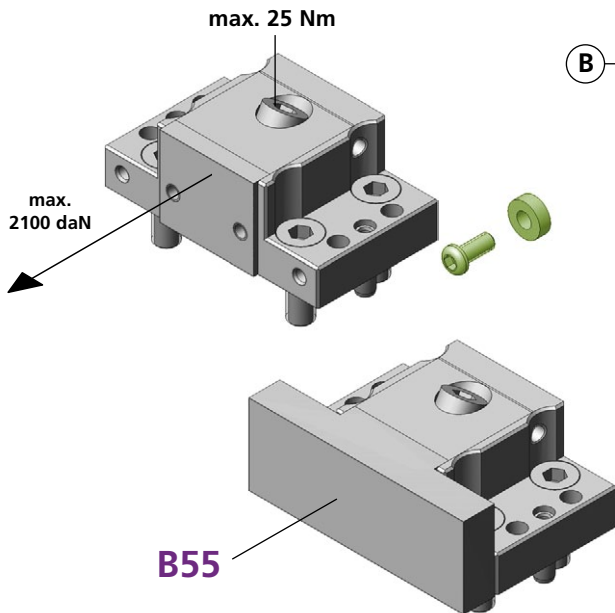
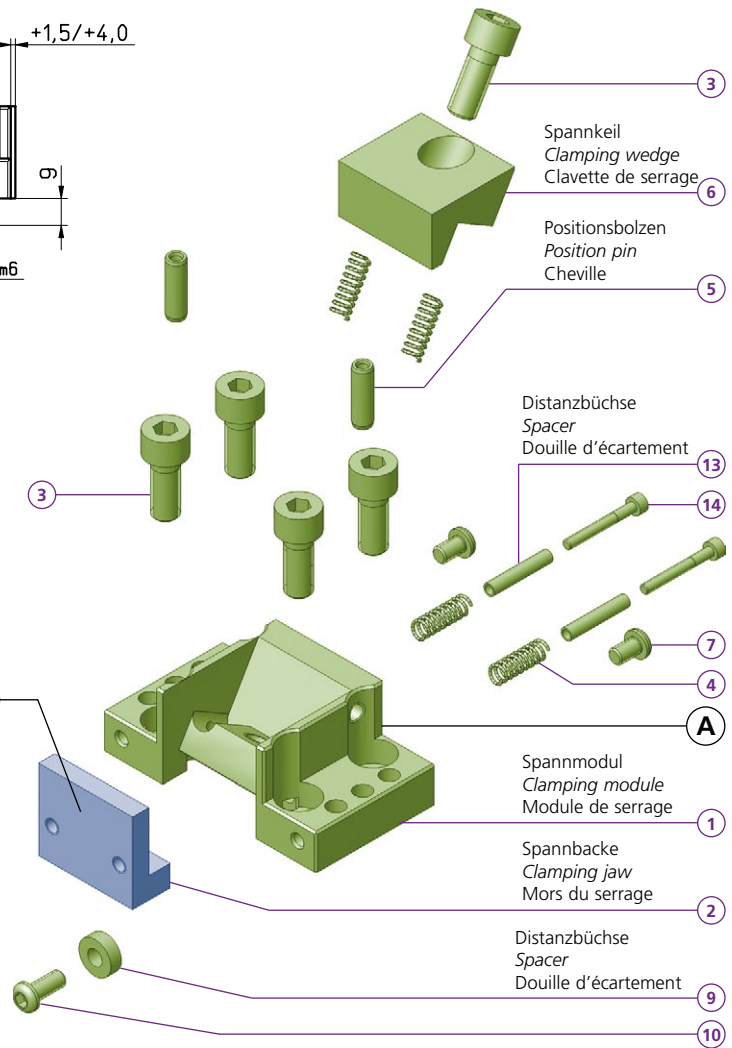
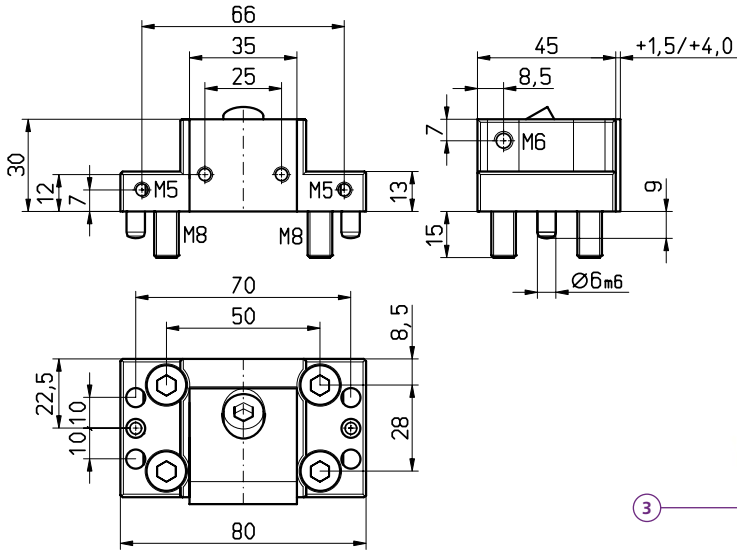

Bestellbeispiel / Ordering example / Exemple de commande:  
1x VS1R 41L30 & 1x B51

VS1F 41L30 -51	
1	1x TF140727
VS1R 41L30 -51	
1	1x TF140728
2	1x
3	5x M8x20 ISO 4762
4	4x FED 0618
5	2x CCBO 0802
6	1x B78
7	2x M5x8 ISO 7380
9	2x CCD 004
10	2x M5x12 ISO 7380
13	2x CCD 422
14	2x M3x25 ISO 4762
kg	~0,545 (B55 = ~0,95)

	B51	B52	B53	B54	B55
C	35	35	35	35	80
H	30	30	30	35	30
L	6	6	10	10	11,5
D	-	-	-	-	-
G	-	-	-	-	-
i	56 HRC	56 HRC	*	*	*

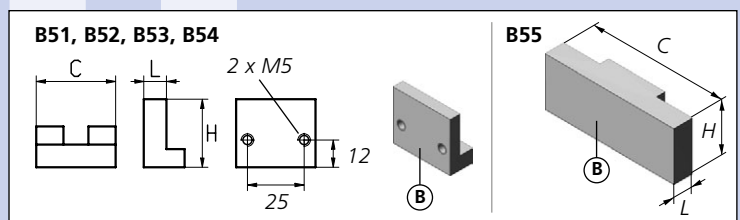





# VS1R/F 41N30 -60

# microCLAMP

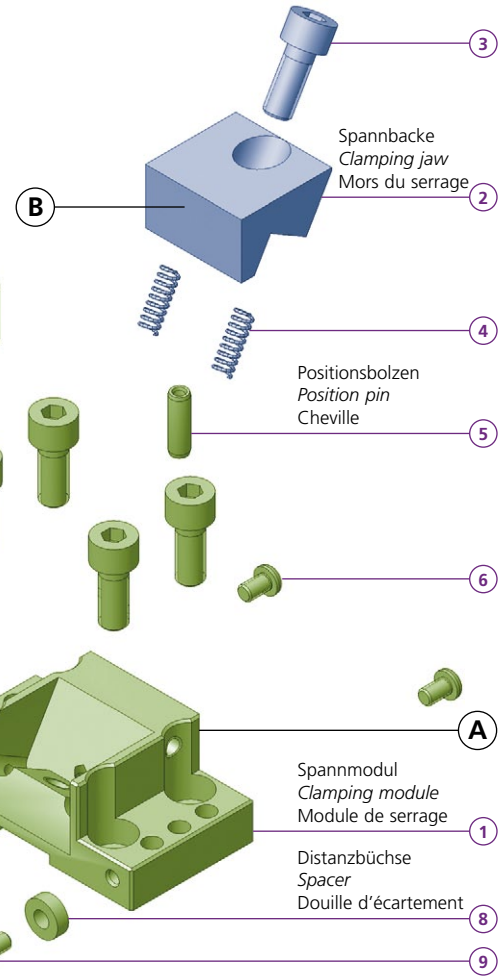
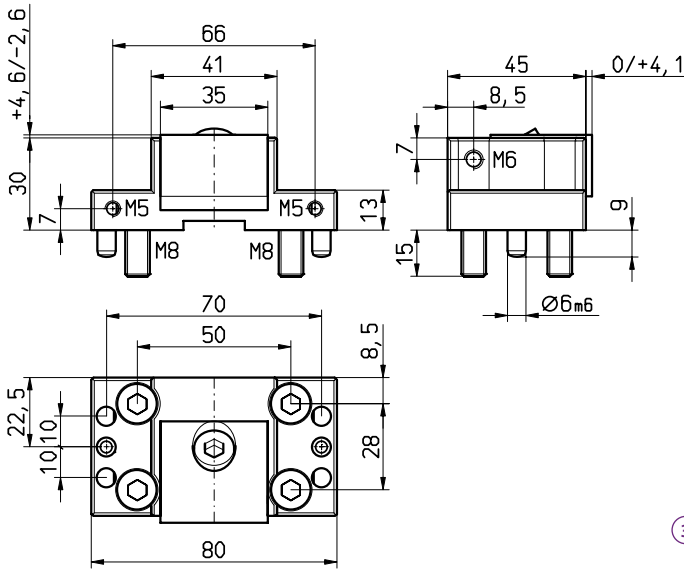

## VS1F 41N30 -60

1x TF140729

## VS1R 41N30 -60

1x TF140730

1x

5x M8x20 ISO 4762

2x FED 0618

2x CCBO 0802

2x M5x8 ISO 7380

2x CCD 004

2x M5x12 ISO 7380

kg ~0,58

max. 25 Nm

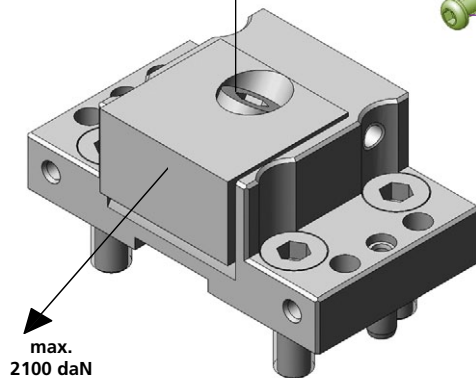

### Bestellbeispiel / Ordering example / Exemple de commande:

1x VS1R 41N30 & 1x B60

	B58	B60	B61	B62	B62HM	B65	B66	B67	B68	B69	B77	B79	B79R
C	35	35	35	35	35	35	35	35	35	35	35	35	35
H	20	20	20	20	20	20	20	20	20	20	20	20	20
L	24	19	19	19	19	19	19	24	26	22	22	25	25
D	9	9	9	9	9	9	9	9	9	9	9	9	9
ø	12	12	12	12	12	12	12	12	12	12	12	12	12
i	ALU *	56 HRC	56 HRC	*	HM	HV700	HV700	HV700	*	*	56 HRC	HV700	HV700
						x0,2mm	x0,2mm	x0,2mm				x0,2mm	x0,2mm

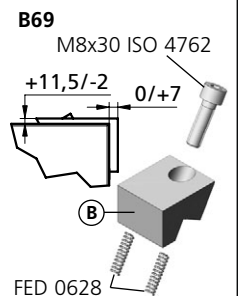

### B58, B60, B61, B62, B62HM

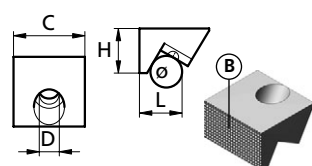

### B65, B66, B67

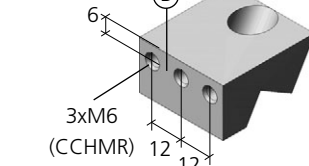

### B68

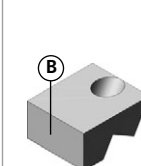

### B77

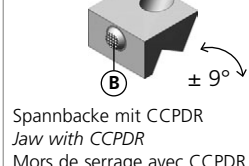

### B79

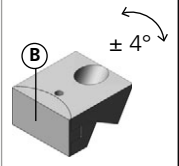

\* = weich / soft / doux

Separat bestellen / Separate order / Commander séparément



# VS1X 68L20 -105

# microCLAMP

## Vorrichtungsbau Modul für Linearbacken

## Fixture clamp module for linear jaws

## Construction de gabarits mors linéaire

Alle bestehenden Linearbacken passen auf dieses Modul.  
 Es wird bloss eine Tasche gefräst um das Modul zu positionieren.  
 Gut geeignet sind die Anschlagbacken Typen **MAND** und **MANF** um als Gegenbacke zu dienen. (p. 136 / p. 137)

All of our standard linear jaws fit to this clamp module.  
 All to do is milling a pocket to fit and positioning the clamp modules.  
 To use the **MAND** and **MANF** as datum stop will make a perfect match. (p. 136 / p. 137)

Tous les modules linéaires peuvent s'adapter dans le moule de cette module.  
 On doit seul usiner une poche pour positionner le module dans la plaque du gabarits.  
 Les modules **MAND** et **MANF** sont propre à prendre comme module fix pour la côté opposé. (p. 136 / p. 137)

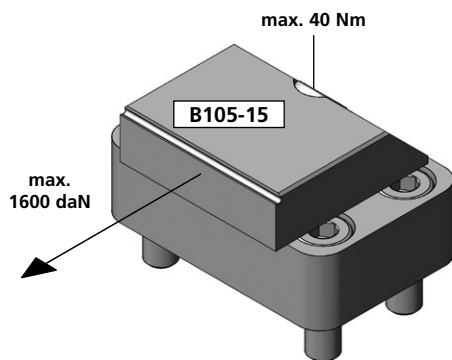
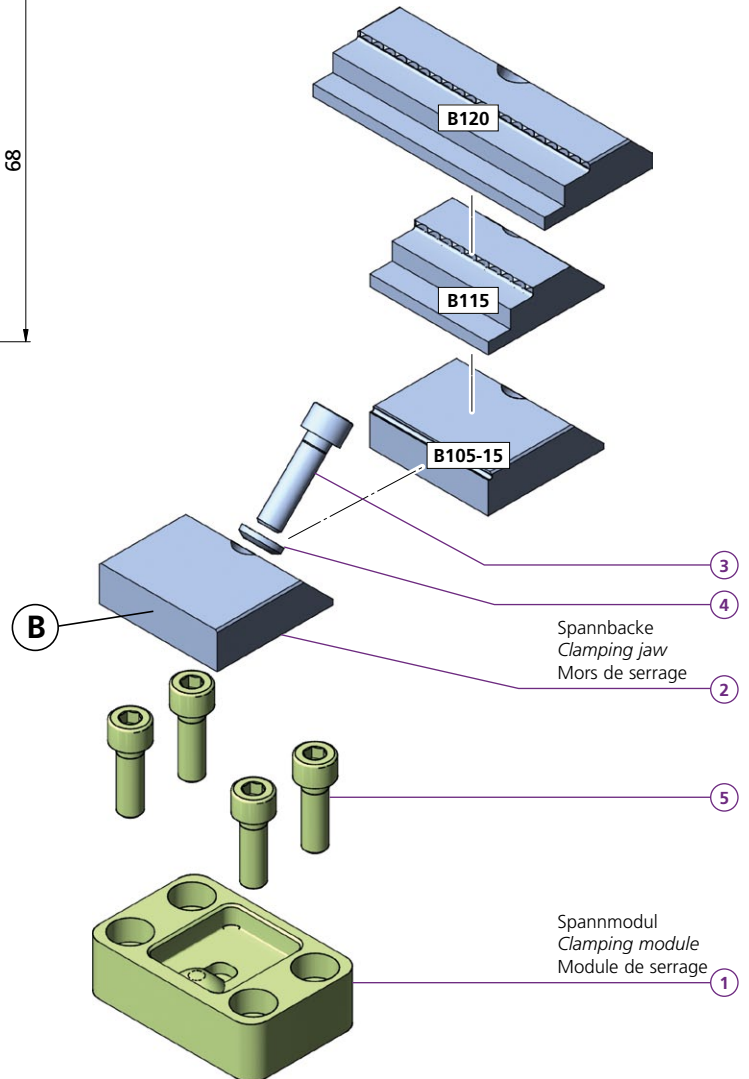
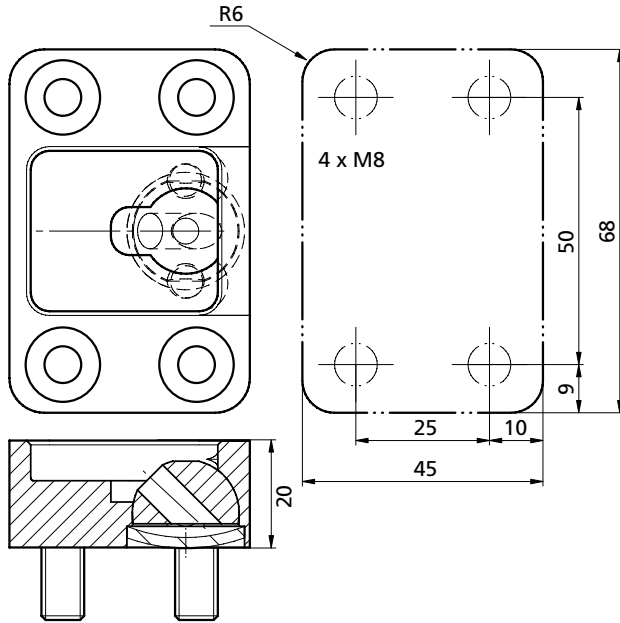

VS1X 68L20 -105	
1	1x TB150170
2	1x  p. 96 - 97 - 98
3	1x M8x25 ISO 4762
4	1x PCUSR 16
5	4x M8x25 DIN 912
kg	~0,41

Bestellbeispiel / Ordering example / Exemple de commande:  
 1x VS1X 68L20 -105 & 1x B105-15

Separat bestellen / Separate order / Commander séparément





**VS1F 48L50 -105**

**VS1P 48L50 -105**

**Linear**

**microCLAMP**

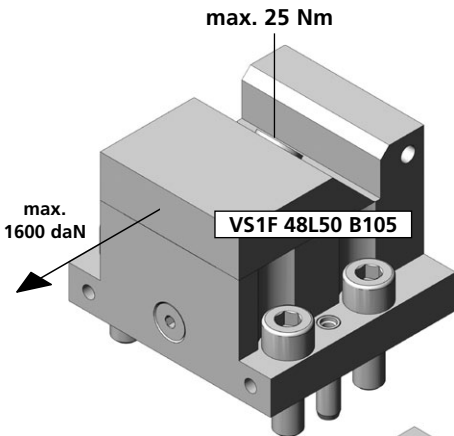
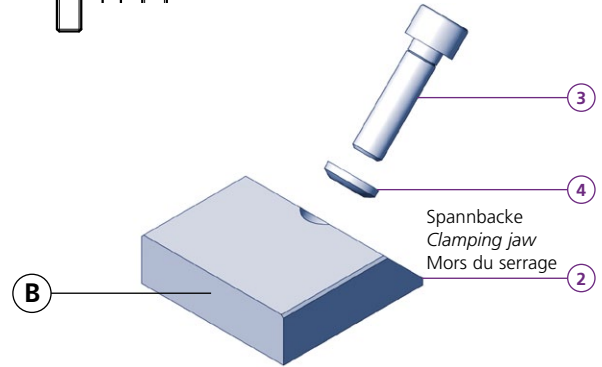
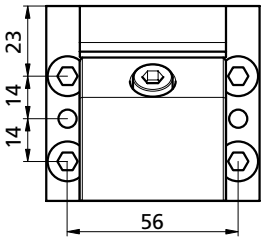
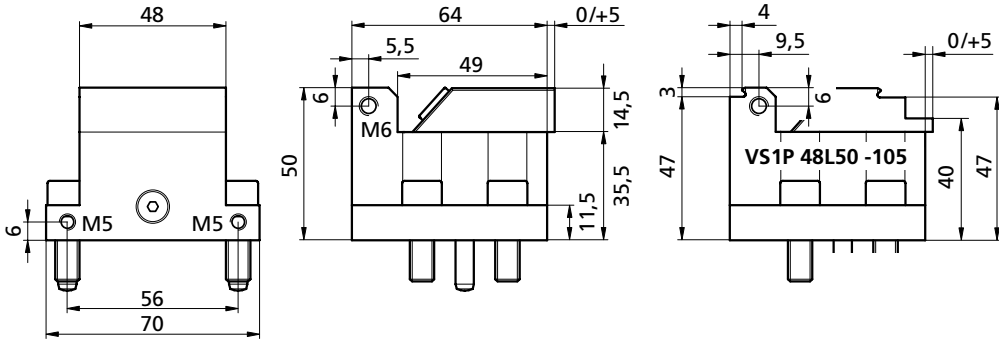

max. 25 Nm

max. 1600 daN

**VS1F 48L50 B105**

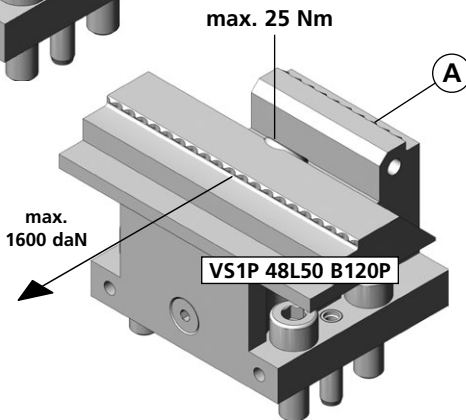

max. 25 Nm

max. 1600 daN

**VS1P 48L50 B120P**

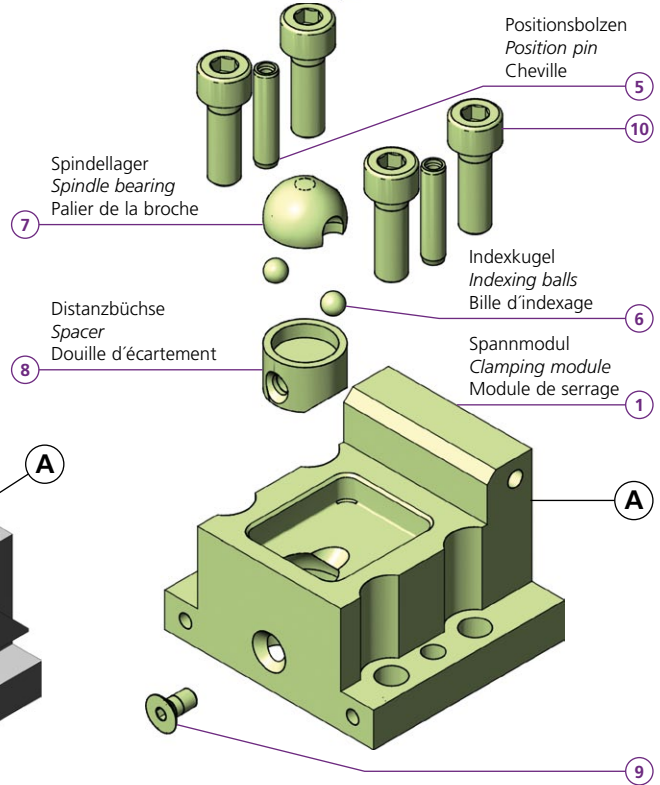

Spannbacke  
Clamping jaw  
Mors du serrage

Spannmodul  
Clamping module  
Module de serrage

Indexkugel  
Indexing balls  
Bille d'indexage

Distanzbüchse  
Spacer  
Douille d'écartement

Spindellager  
Spindle bearing  
Palier de la broche

Positionsbolzen  
Position pin  
Cheville

<b>VS1F 48L50 -105</b>	
1	1x TK120807
<b>VS1P 48L50 -105</b>	
1	1x TK120761
2	1x <b>powerCLAMP</b>
3	1x M8x30 ISO 4762
4	1x PCUSR 14
5	1x 6-m6x26 DIN 79790
6	2x BN 869 d=6
7	1x PCKMR 45 M8
8	2x TS 120001-04
9	1x M5x10 DIN 7991
10	4x M8x25 DIN 912
kg	~1,21

**powerCLAMP** p. 96

Bestellbeispiel / Ordering example / Exemple de commande:  
1x **VS1F 48L50** & 1x **B105**

Separat bestellen / Separate order / Commander séparément



VS1R/F 80L30 -51

Linear

microCLAMP

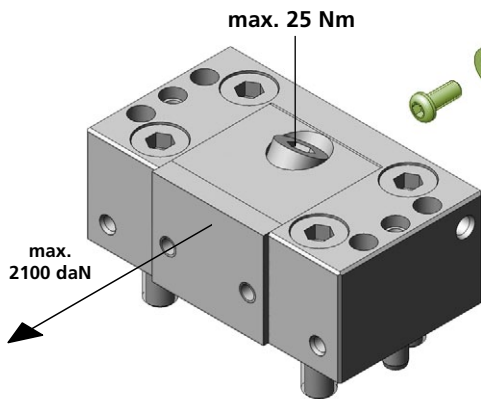
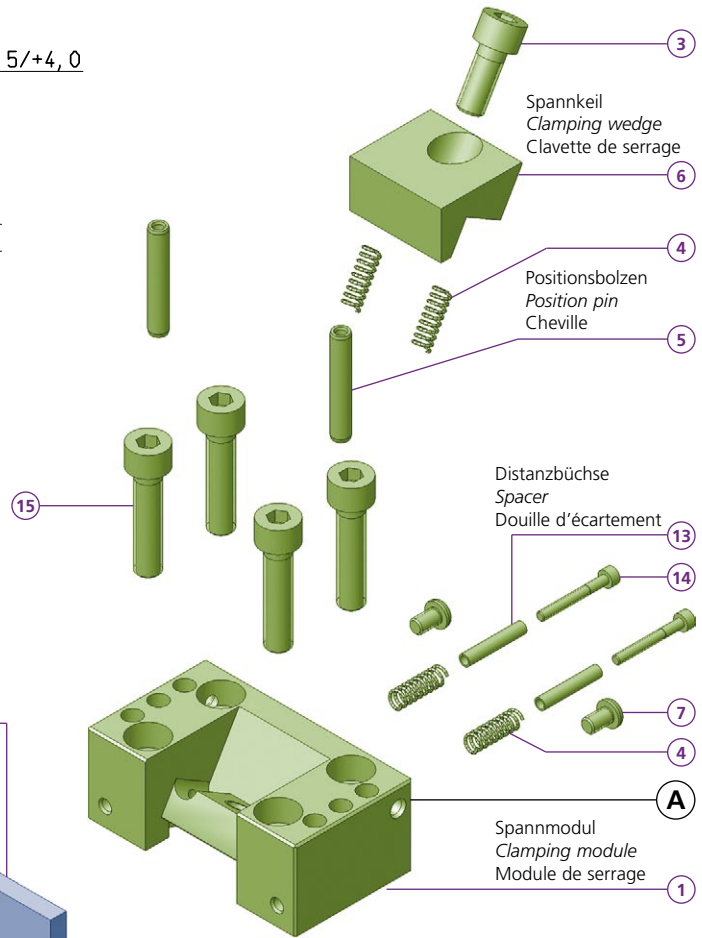
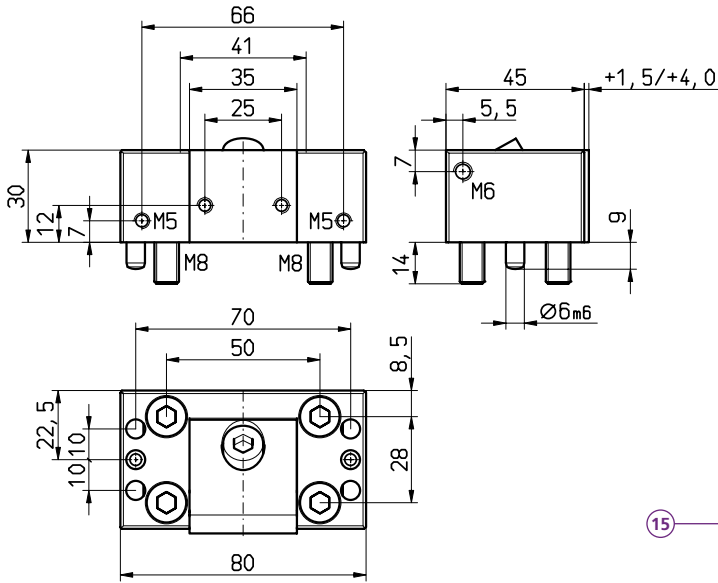

B55

- |                        |          |
|------------------------|----------|
| <b>VS1F 80L30 -51</b>  | <b>A</b> |
| 1x TF140731            | <b>A</b> |
| <b>VS1R 80L30 -51</b>  | <b>B</b> |
| 1x TF140732            | <b>B</b> |
| 1x                     | <b>B</b> |
| 1x M8x20 ISO 4762      | <b>B</b> |
| 4x FED 0618            | <b>B</b> |
| 2x CCBO 0801           | <b>B</b> |
| 1x B78                 | <b>B</b> |
| 2x M5x8 ISO 7380       | <b>B</b> |
| 2x CCD 004             | <b>B</b> |
| 2x M5x12 ISO 7380      | <b>B</b> |
| 2x CCD 422             | <b>B</b> |
| 2x M3x25 ISO 4762      | <b>B</b> |
| 4x M8x35 ISO 4762      | <b>B</b> |
| kg ~0,74 (B55 = ~0,95) |          |

Bestellbeispiel / Ordering example / Exemple de commande:  
1x VS1R 80L30 & 1x B51

	B51	B52	B53	B54	B55
<b>C</b>	35	35	35	35	80
<b>H</b>	30	30	30	35	30
<b>L</b>	6	6	10	10	11,5
<b>D</b>	-	-	-	-	-
<b>G</b>	-	-	-	-	-
<b>i</b>	HV700 x0,2mm	HV700 x0,2mm	*	*	*

B51, B52, B53, B54

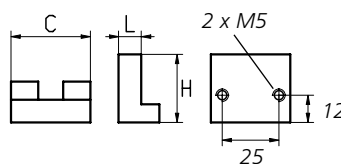

B55

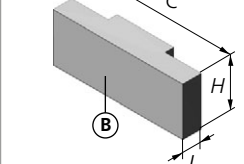



# VS1R/F 80N30 -36

# VS1R 80N50 -36

## microCLAMP

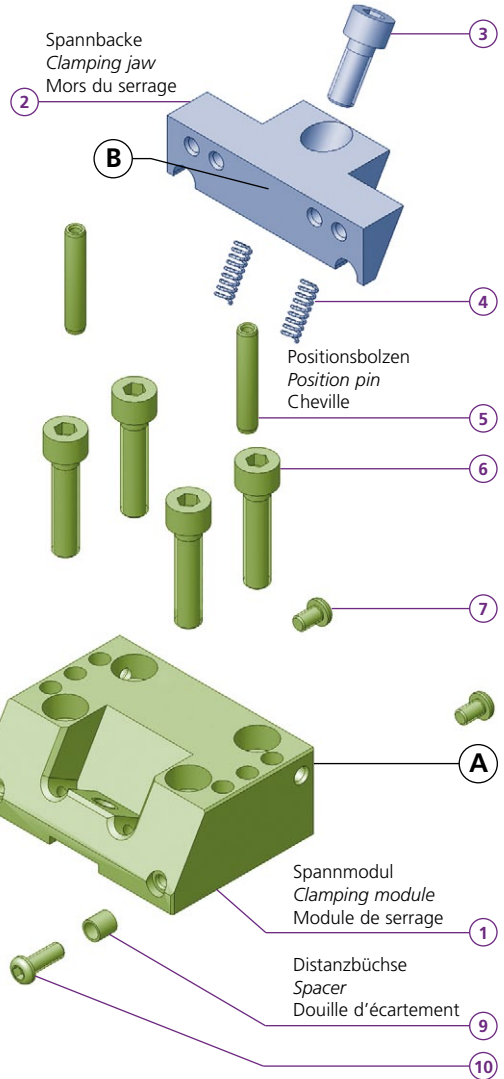
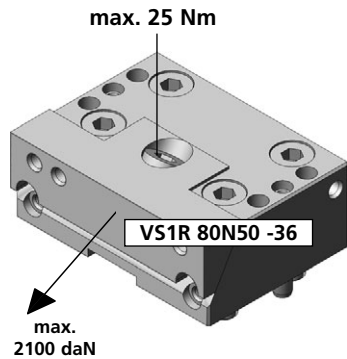
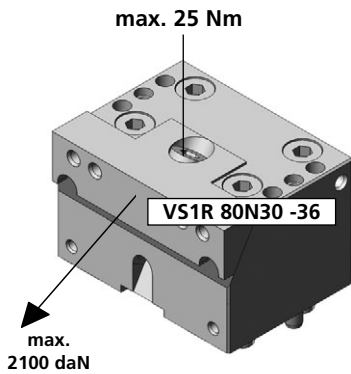
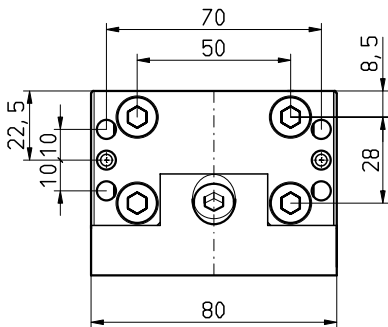
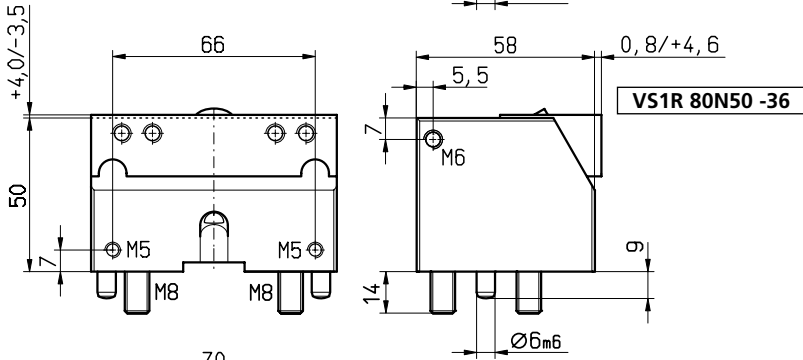
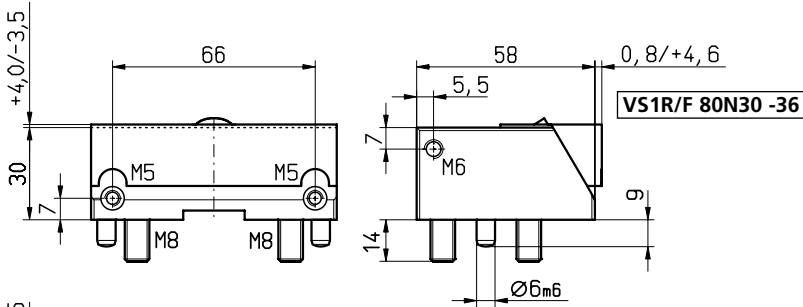

Bestellbeispiel / Ordering example / Exemple de commande:  
1x VS1R 80N30 & 1x B36

<b>VS1F 80N30 -36</b>	
1x TF140733	
<b>VS1R 80N30 -36</b>	
1x TF140734	
2x CCBO 0801	
4x M8x35 ISO 7380	
2x M5x8 ISO 4762	
2x CCD 007	
2x M5x16 ISO 7380	
<b>kg</b>	~1,2

<b>VS1R 80N50 -36</b>	
1x TF140742	
2x CCBO 0803	
4x M8x55 ISO 7380	
2x CCD 005	
2x M5x12 ISO 7380	
<b>kg</b>	~1,9

	B36	B37	B38
<b>B</b>			
<b>C</b>	80	80	80
<b>H</b>	20	20	20
<b>L</b>	19	19	19
<b>D</b>	9	9	9
<b>e</b>	12	12	12
<b>i</b>	HV700 x0,2mm	HV700 x0,2mm	*

**B36, B37, B38**

\* = weich / soft / doux

Separat bestellen / Separate order / Commander séparément





# VS1R/F 80N30 -60

# microCLAMP

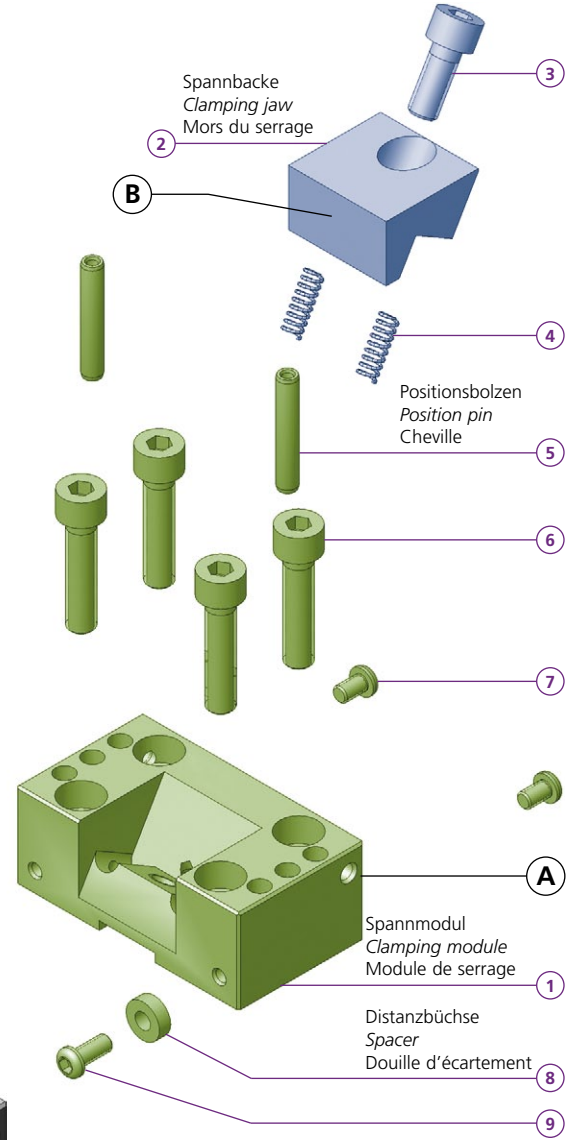
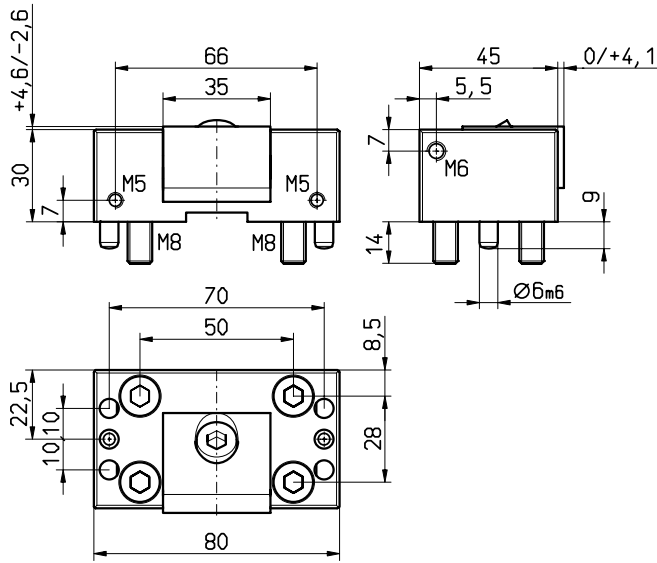

- VS1F 80N30 -60**
- 1 1x TF140735
- VS1R 80N30 -60**
- 1 1x TF140736
  - 2 1x
  - 3 1x M8x20 ISO 4762
  - 4 2x FED 0618
  - 5 2x CCBO 0801
  - 6 4x M8x35 ISO 4762
  - 7 2x M5x8 ISO 7380
  - 8 2x CCD 004
  - 9 2x M5x12 ISO 7380
  - kg ~0,74

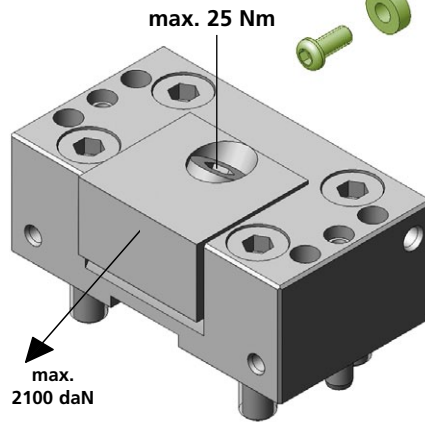

### Bestellbeispiel / Ordering example / Exemple de commande:

1x VS1F 80N30 & 1x B60

	B58	B60	B61	B62	B62HM	B65	B66	B67	B68	B69	B77	B79	B79R
<b>C</b>	35	35	35	35	35	35	35	35	35	35	35	35	35
<b>H</b>	20	20	20	20	20	20	20	20	20	20	20	20	20
<b>L</b>	24	19	19	19	19	19	19	24	26	22	22	25	25
<b>D</b>	9	9	9	9	9	9	9	9	9	9	9	9	9
<b>e</b>	12	12	12	12	12	12	12	12	12	12	12	12	12
<b>i</b>	ALU *	56 HRC	56 HRC	*	HM	HV700 x0,2mm	HV700 x0,2mm	HV700 x0,2mm	*	*	56 HRC	HV700 x0,2mm	HV700 x0,2mm

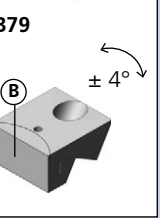
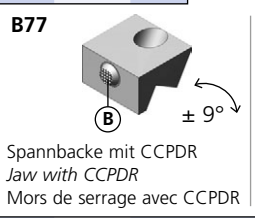
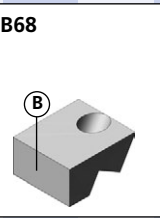
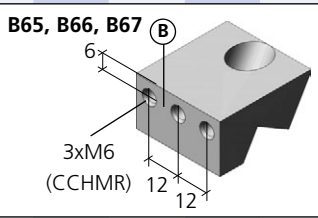
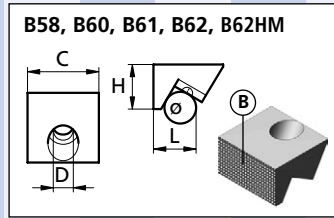
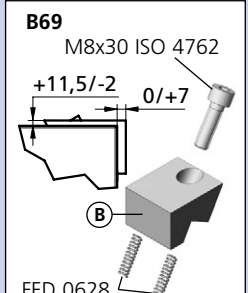

Separat bestellen / Separate order / Commander séparément



# VS1R 80N50 -60

# microCLAMP

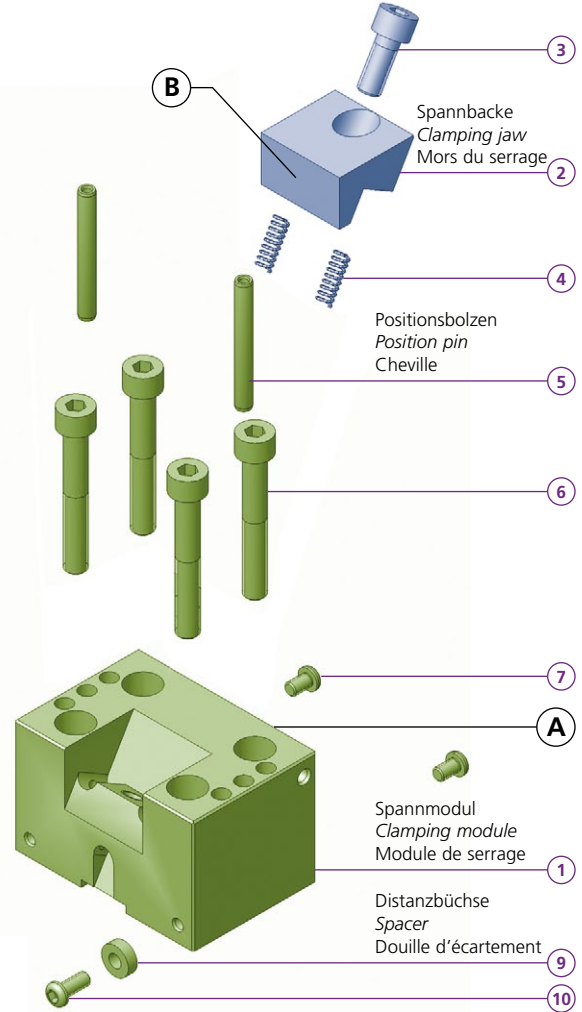
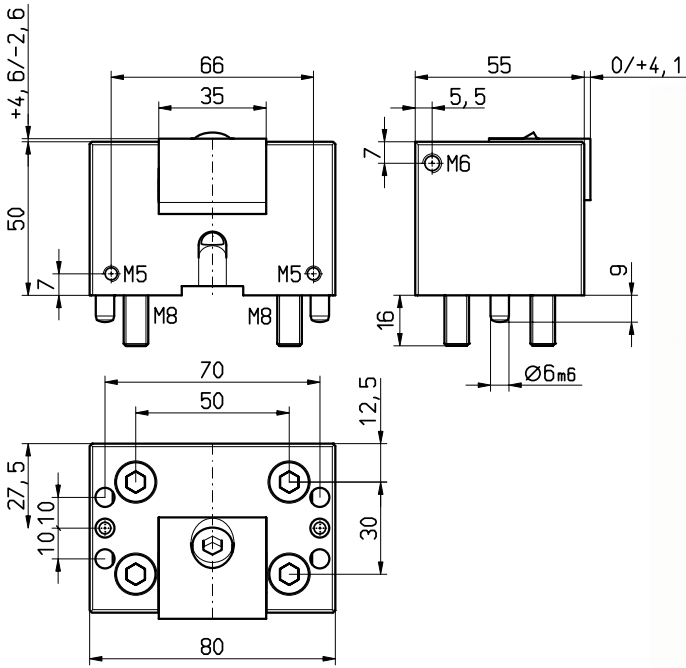

VS1R 80N50 -60	
1	1x TF140737
2	1x
3	1x M8x20 ISO 4762
4	2x FED 0618
5	2x CCBO 0803
6	4x M8x55 ISO 4762
7	2x M5x8 ISO 7380
9	2x CCD 004
10	2x M5x12 ISO 7380
kg	~1,6

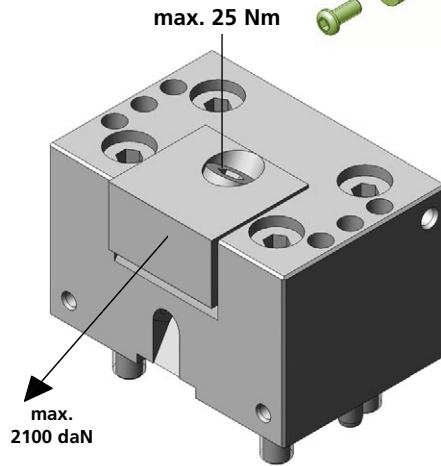

Bestellbeispiel / Ordering example / Exemple de commande:  
1x VS1R 80N50 & 1x B60

	B58	B60	B61	B62	B62HM	B65	B66	B67	B68	B69	B77	B79	B79R
C	35	35	35	35	35	35	35	35	35	35	35	35	35
H	20	20	20	20	20	20	20	20	20	20	20	20	20
L	24	19	19	19	19	19	19	24	26	22	22	25	25
D	9	9	9	9	9	9	9	9	9	9	9	9	9
ø	12	12	12	12	12	12	12	12	12	12	12	12	12
i	ALU *	56 HRC	56 HRC	*	HM	HV700 x0,2mm	HV700 x0,2mm	HV700 x0,2mm	*	*	56 HRC	HV700 x0,2mm	HV700 x0,2mm

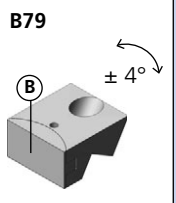
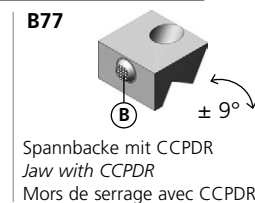
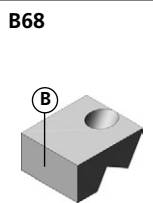
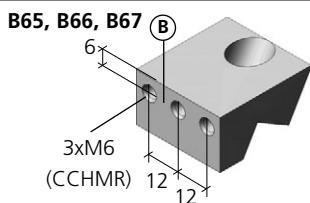
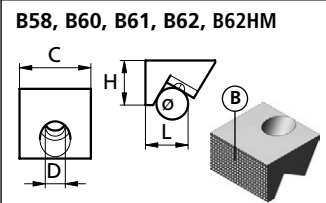
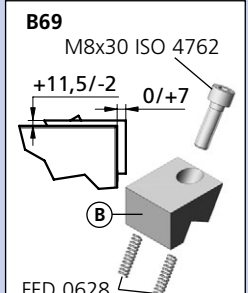

\* = weich / soft / doux

Separat bestellen / Separate order / Commander séparément



# VS1R/F 125N49 -95

microCLAMP

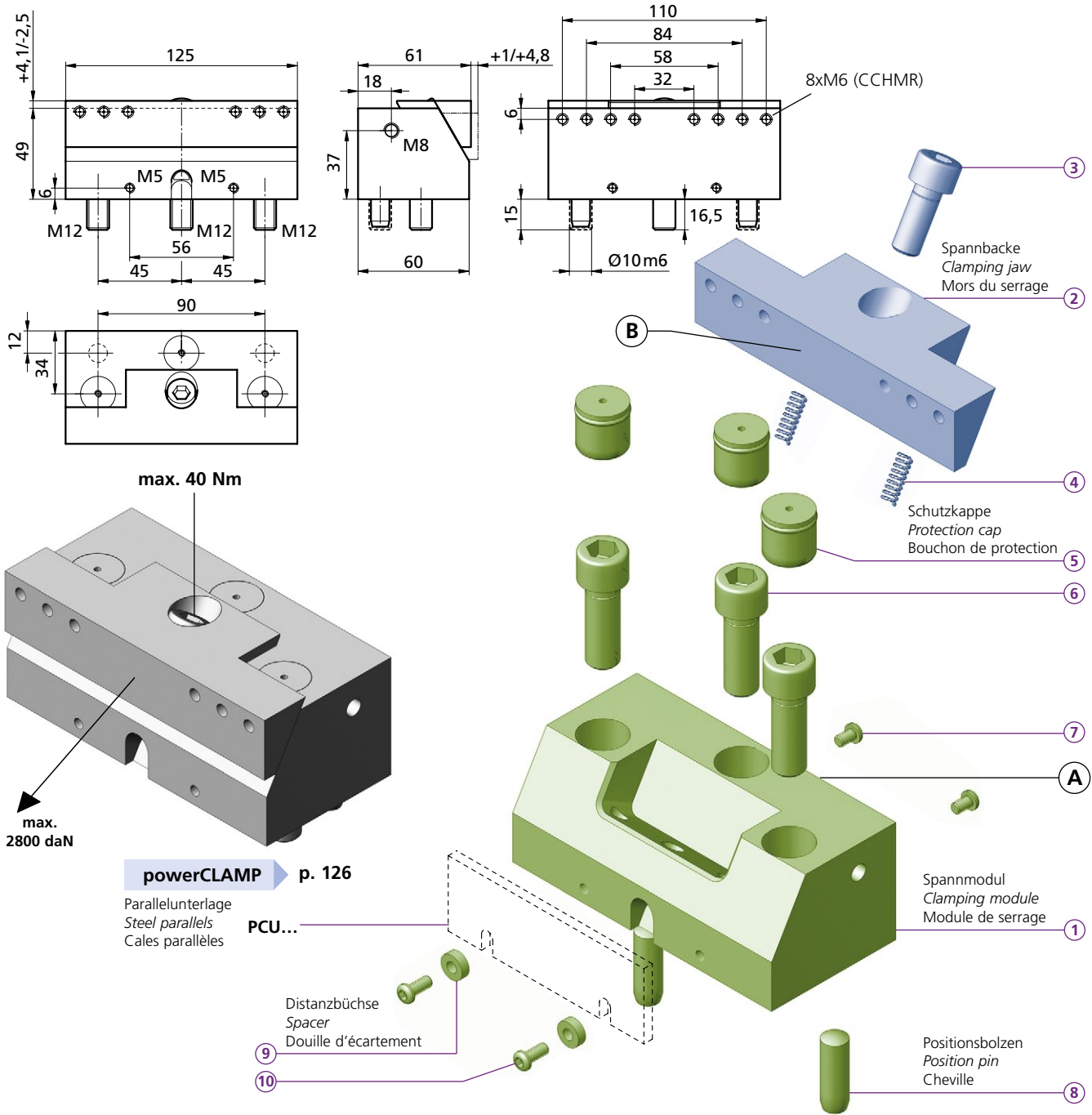

Bestellbeispiel / Ordering example / Exemple de commande:  
1x VS1R 125N49 & 1x B95

<b>VS1F 125N49 -95</b>	<b>VS1R 125N49 -95</b>
1x TF140738	1x TF140739
1x	
1x M10x25 ISO 4762	
2x FED 0618	
3x PCPF 16L18 Alu	
3x M12x35 ISO 4762	
3x M5x8 ISO 7380	
2x 10m 6x30 ISO 8734	
2x CCD 004	
2x M5x12 ISO 7380	
kg ~2,6	

	B95	B96	B97	B98	B99
<b>C</b>	125	125	125	125	125
<b>H</b>	25	25	25	25	25
<b>L</b>	23	23	23	30	23
<b>D</b>	11	11	11	11	11
<b>e</b>	15	15	15	15	15
<b>i</b>	HV700 x0,2mm	HV700 x0,2mm	*	*	HV700 x0,2mm

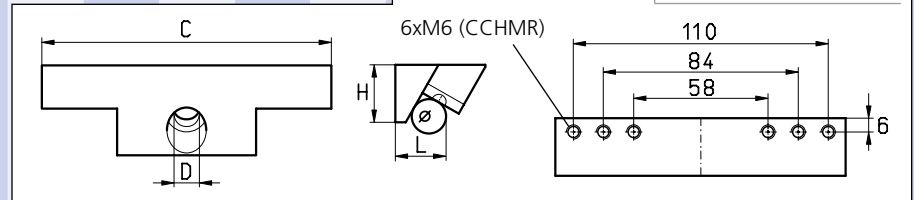
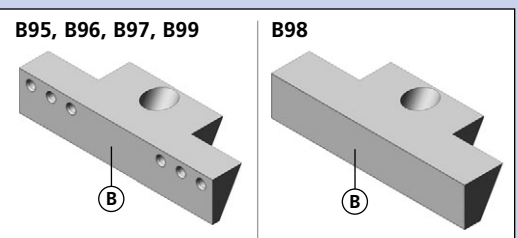





# VS2R 80N30 -60

microCLAMP

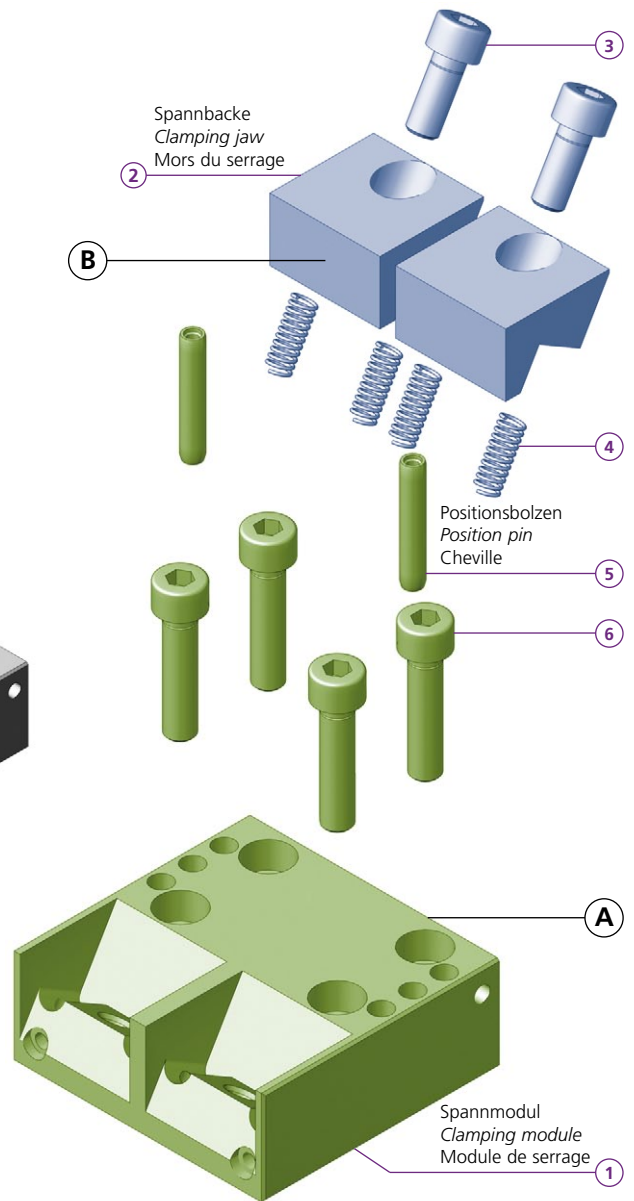
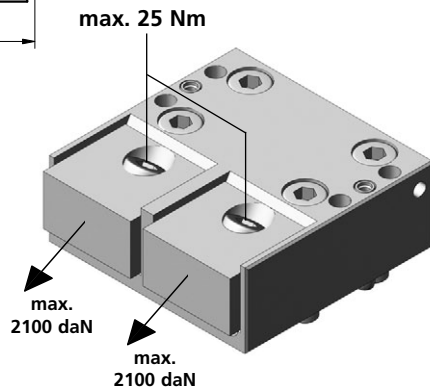
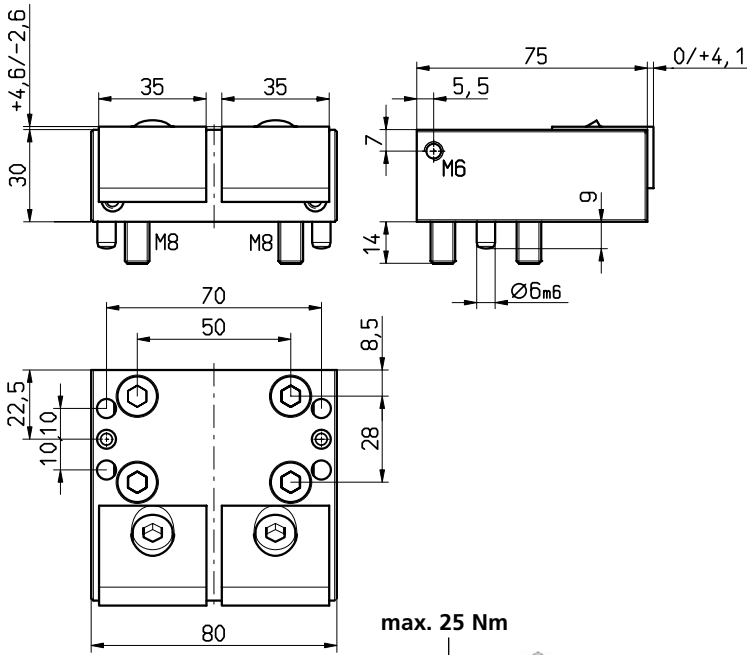

**VS2R 80N30 -60**

1	1x	TF140740
2	2x	
3	2x	M8x20 ISO 4762
4	4x	FED 0618
5	2x	CCBO 0801
6	4x	M8x35 ISO 4762
kg		~1,3

Bestellbeispiel / Ordering example / Exemple de commande:  
1x VS2R 80N30 & 2x B60

	B58	B60	B61	B62	B62HM	B65	B66	B67	B68	B69	B77	B79	B79R
C	35	35	35	35	35	35	35	35	35	35	35	35	35
H	20	20	20	20	20	20	20	20	20	20	20	20	20
L	24	19	19	19	19	19	19	24	26	22	22	25	25
D	9	9	9	9	9	9	9	9	9	9	9	9	9
ø	12	12	12	12	12	12	12	12	12	12	12	12	12
i	ALU *	56 HRC	56 HRC	*	HM	HV700 x0,2mm	HV700 x0,2mm	HV700 x0,2mm	*	*	56 HRC	HV700 x0,2mm	HV700 x0,2mm

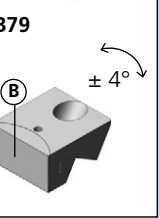
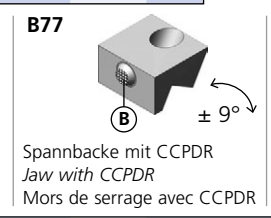
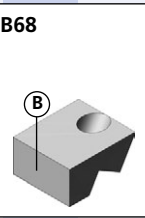
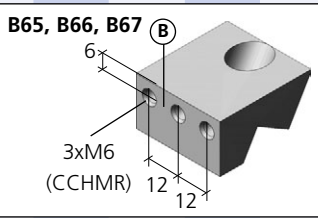
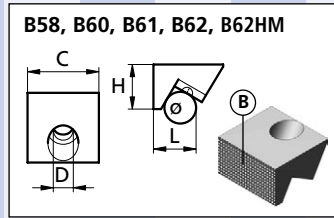
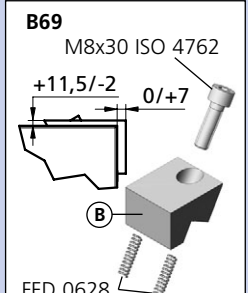

\* = weich / soft / doux

Separat bestellen / Separate order / Commander séparément



# VS2F 90N30 -60

# microCLAMP

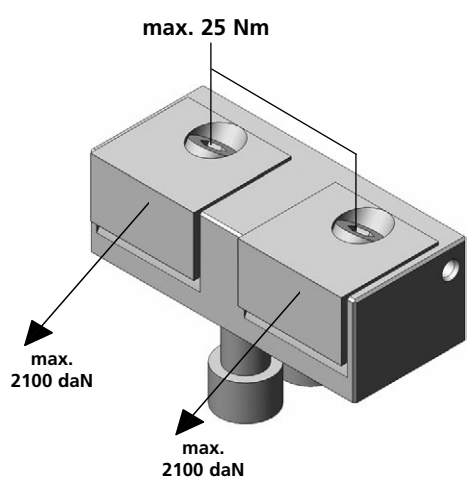
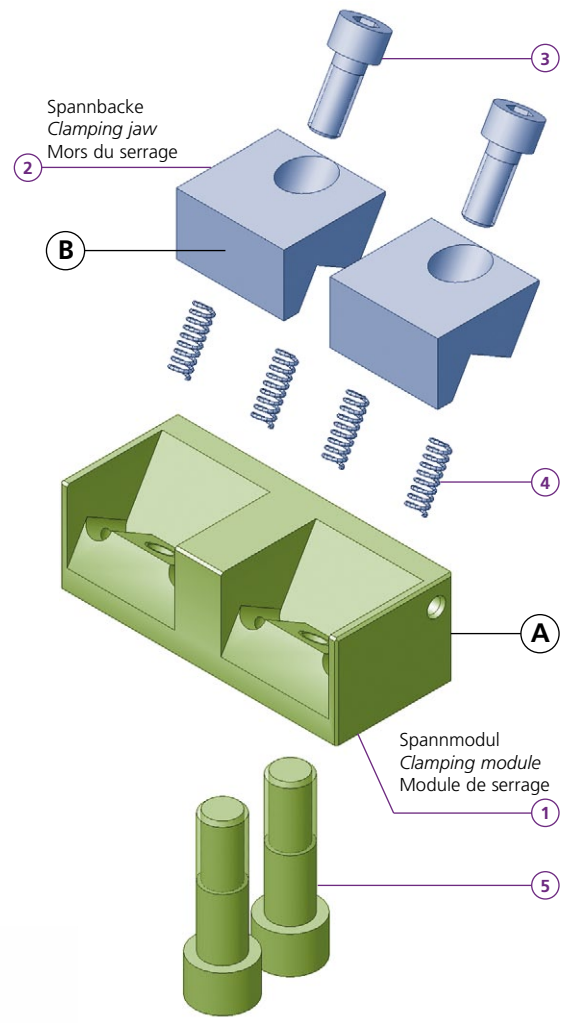
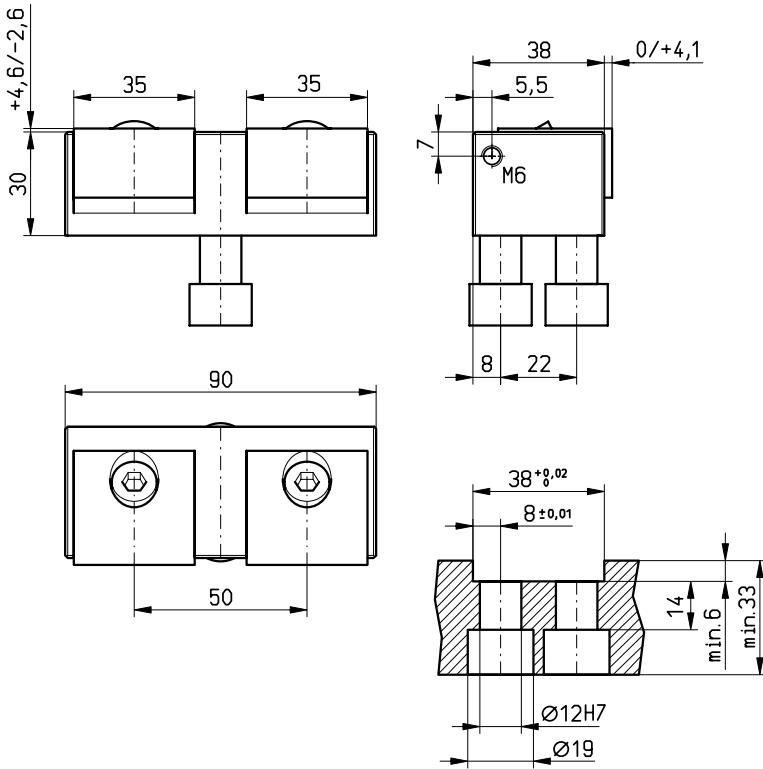

**VS2F 90N30 -60**

1	1x	TF140741
2	2x	
3	2x	M8x30 ISO 4762
4	4x	FED 0618
5	2x	TWPAS 1232
kg		~0,85

Bestellbeispiel / Ordering example / Exemple de commande:  
1x VS2F 90N30 & 2x B60

	B58	B60	B61	B62	B62HM	B65	B66	B67	B68	B69	B77	B79	B79R
<b>C</b>	35	35	35	35	35	35	35	35	35	35	35	35	35
<b>H</b>	20	20	20	20	20	20	20	20	20	20	20	20	20
<b>L</b>	24	19	19	19	19	19	19	24	26	22	22	25	25
<b>D</b>	9	9	9	9	9	9	9	9	9	9	9	9	9
<b>ø</b>	12	12	12	12	12	12	12	12	12	12	12	12	12
<b>i</b>	ALU *	56 HRC	56 HRC	*	HM	HV700 x0,2mm	HV700 x0,2mm	HV700 x0,2mm	*	*	56 HRC	HV700 x0,2mm	HV700 x0,2mm

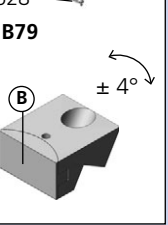
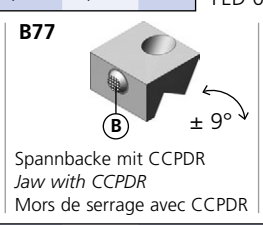
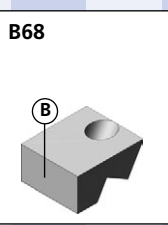
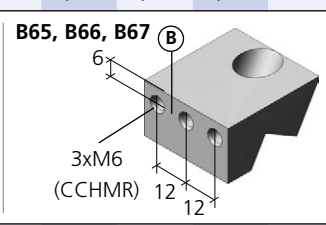
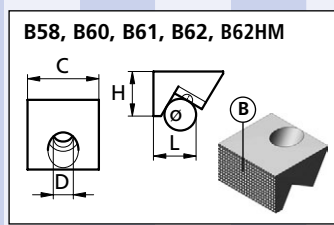
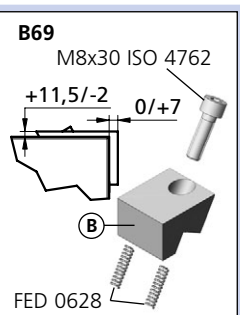



**VS1X 59L60 K**

**Linear**

**microCLAMP**

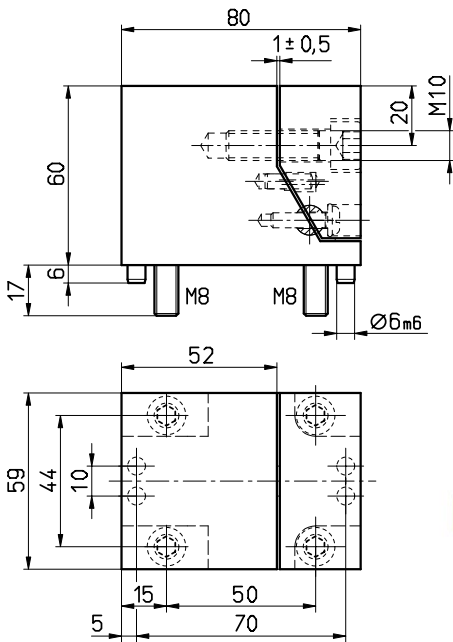

Empfohlener Sechskantschlüssel  
Recommended hexagon wrench  
Clé hexagonale recommandée  
**PB 2212 L/6 (SWISS TOOLS)**

100°

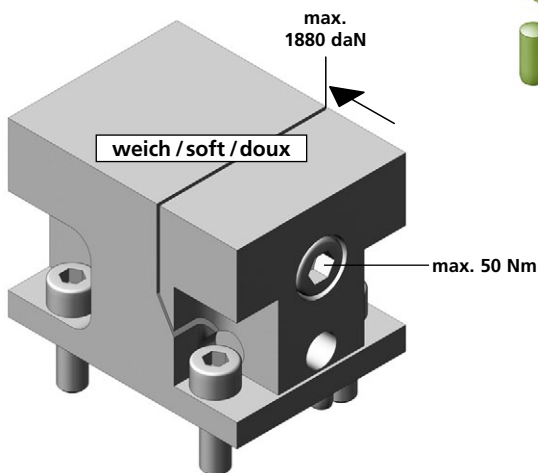
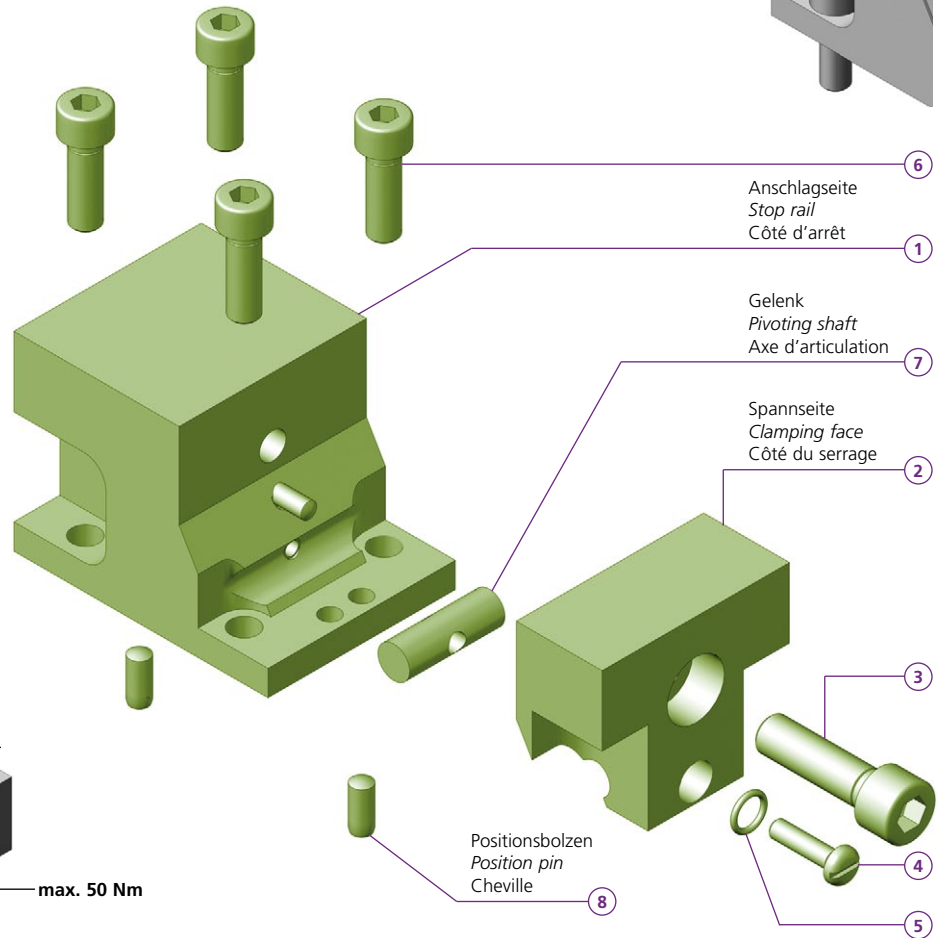
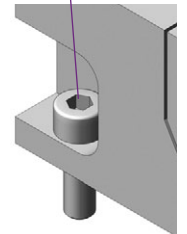

Anwendungsbeispiel  
Application example  
Exemple d'application

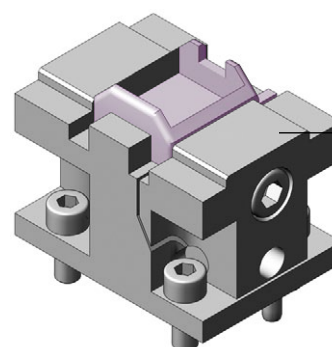

Spannstelle an Werkstück  
angepasst und nitriert.  
Clamping face machined to  
the shape of the workpiece  
and nitrided.  
Position de serrage adap-  
tée à la pièce et nitrurée.

**\* VS1X 59L60 K**

- ① 1x T00296
  - ② 1x T00295
  - ③ 1x M10x35 ISO 4762
  - ④ 1x M5x20 BN 344
  - ⑤ 1x OR Ø 8x1,5
  - ⑥ 4x M8x25 ISO 4762
  - ⑦ 1x VSX59L60KG
  - ⑧ 2x 6m 6x14 DIN 6325
- kg ~1,89

\* = Stahl / Steel / Acier 1.2312

Bestellbeispiel / Ordering example / Exemple de commande: **VS1X 59L60 K**





**VS1X 59L60 H5**

**Linear**

**microCLAMP**

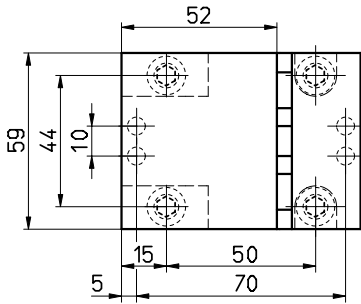
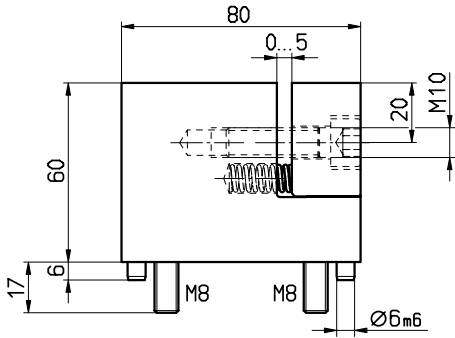

Empfohlener Sechskantschlüssel  
Recommended hexagon wrench  
Clé hexagonale recommandée  
**PB 2212 L/6 (SWISS TOOLS)**

100°

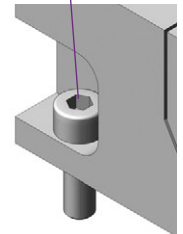

Anschlagseite  
Stop rail  
Côté d'arrêt

1

Spannseite  
Clamping face  
Côté du serrage

2

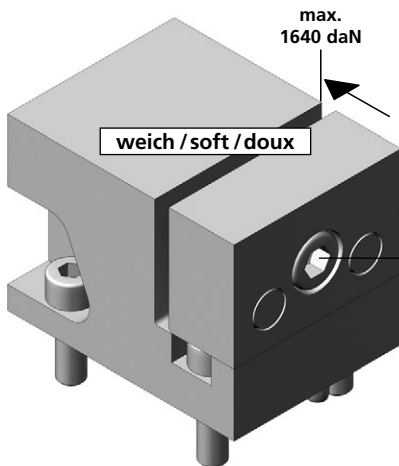

max.  
1640 daN

weich / soft / doux

max. 50 Nm

Positionsbolzen  
Position pin  
Cheville

8

Anwendungsbeispiele  
Sample applications  
Exemples d'applications

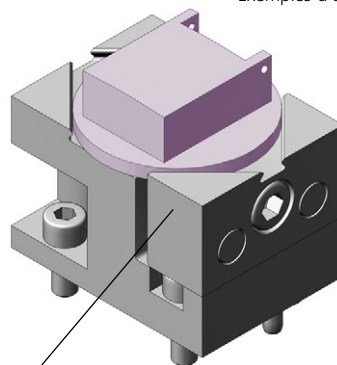

Spannstelle an Werkstück angepasst und nitriert.  
Clamping face machined to the shape of the workpiece and nitrided.  
Position de serrage adaptée à la pièce et niturée.

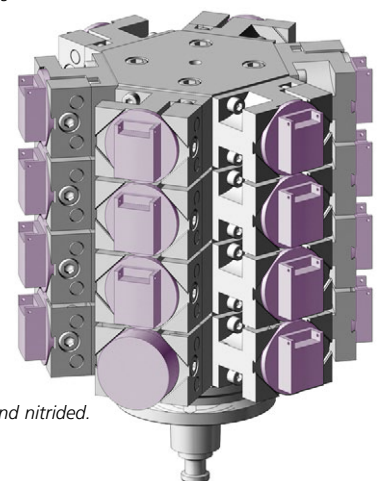

**\* VS1X 59L60 H5**

- 1 1x T00316
- 2 1x T00315
- 3 1x M10x35 ISO 4762
- 6 2x M8x25 ISO 4762
- 7 1x FED 0833
- 8 2x 6m 6x14 DIN 6325
- 9 2x M8x30 ISO 4762

kg ~1,94

\* = Stahl / Steel / Acier 1.2312

Bestellbeispiel / Ordering example / Exemple de commande: **VS1X 59L60 H5**



durchgehärtet / through hardened / trempé						nitriert / nitrated / nitruré									
<b>H</b>	<b>26mm</b>	<b>B</b>	<b>N</b>	<b>H</b>	<b>41mm</b>	<b>B</b>	<b>N</b>	<b>H</b>	<b>23mm</b>	<b>B</b>	<b>N</b>	<b>H</b>	<b>41mm</b>	<b>B</b>	<b>N</b>
15	CCU 15026	26	2,2	15	CCU 15081	41	2,2	11	MCU 11037	23	2	15	CCU 15083	41	3
20	CCU 20026	26	2,2	20	CCU 20081	41	2,2	15	MCU 15037	23	2	20	CCU 20083	41	3
25	CCU 25026	26	2,2	25	CCU 25081	41	2,2	18	MCU 18037	23	2	25	CCU 25083	41	3
30	CCU 30026	26	2,2	27,5	CCU 27581	41	2,2	20	MCU 20037	23	2	27,5	CCU 27583	41	3
32,5	CCU 32526	26	2,2	30	CCU 30081	41	2,2	22,5	MCU 22537	23	2				
<b>H</b>	<b>38mm</b>	<b>B</b>	<b>N</b>	<b>H</b>	<b>80mm</b>	<b>B</b>	<b>N</b>	<b>H</b>	<b>26mm</b>	<b>B</b>	<b>N</b>	<b>H</b>	<b>80mm</b>	<b>B</b>	<b>N</b>
30	CCU 30039	38	2,2	15	CCU 15080	79	2,2	15	CCU 15027	26	3	15	CCU 15082	79	3
35	CCU 35039	38	2,2	20	CCU 20080	79	2,2	20	CCU 20027	26	3	20	CCU 20082	79	3
40	CCU 40039	38	2,2	25	CCU 25080	79	2,2	25	CCU 25027	26	3	25	CCU 25082	79	3
45	CCU 45039	38	2,2	27,5	CCU 27580	79	2,2	30	CCU 30027	26	3	27,5	CCU 27582	79	3
				30	CCU 30080	79	2,2	32,5	CCU 32527	26	3				
				35	CCU 35080	79	2,2								
				40	CCU 40080	79	2,2								
				45	CCU 45080	79	2,2								

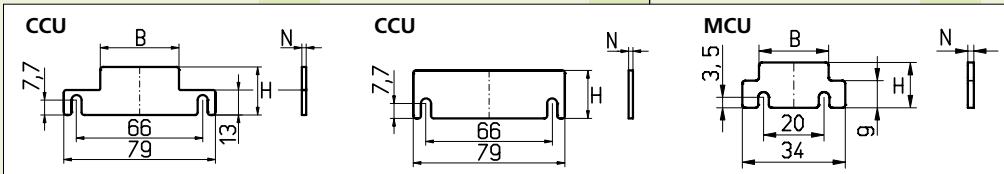

**Schraubenzieher mit Konterung**  
**Screwdriver with holding sleeve**  
**Tournevis pour chevilles extensibles**

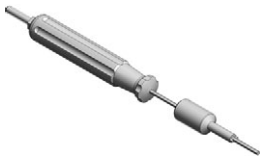

CCBX SK

**Positionsbolzen**  
**Position pin**  
**Cheville de positionnement**

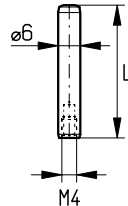

	L
CCBO 0801	36
CCBO 0802	20
CCBO 0803	50

**Bolzen-Auszieher**  
**Pin puller**  
**Extracteur de chevilles**

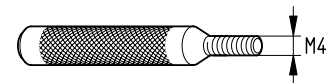

CCAZ 1050

**Positionierstift (spreizbar)**  
**Locating pin (expandable)**  
**Goupille d'arrêt (extensible)**



CCBX 0802



MCZ 100 L50

Mehr Informationen siehe Zentrischspanner  
For more information check the self centring vise (Seite / Page / Page 256)  
Pour plus d'informations visiter le étau auto centrant

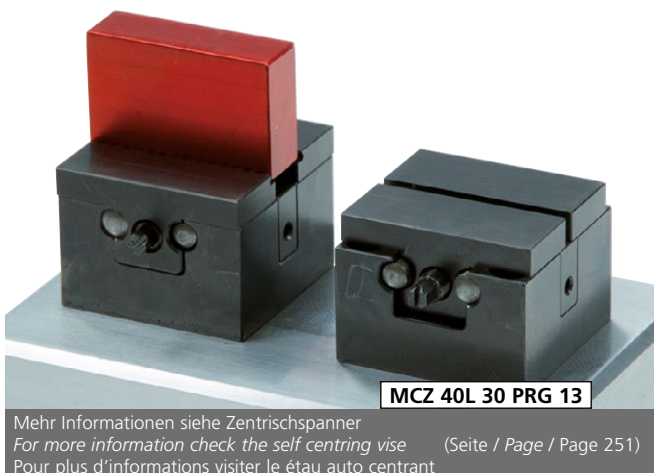

MCZ 40L 30 PRG 13

Mehr Informationen siehe Zentrischspanner  
For more information check the self centring vise (Seite / Page / Page 251)  
Pour plus d'informations visiter le étau auto centrant



CC ...  
CC ... V

**Universalbacke / Universal jaw / Mors universel**

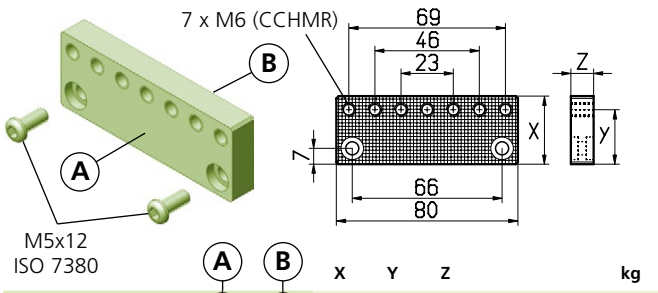

	A	B	x	y	z		kg
CC 8011			30	24	10	56 HRC	~ 0,15
CC 8025			50	44	10	56 HRC	~ 0,28
CC 8040*			30	29	20	*	~ 0,33

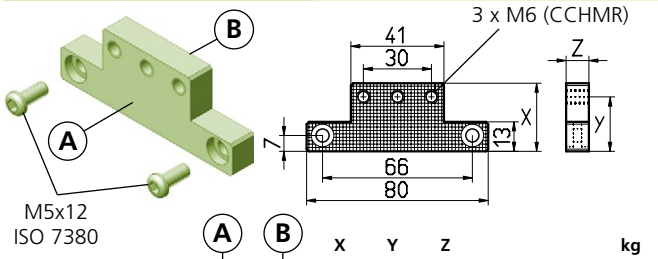

	A	B	x	y	z		kg
CC 8021			30	24	10	56 HRC	~ 0,11
CC 8026			50	44	10	56 HRC	~ 0,17
CC 8041*			30	24	20	*	~ 0,24

**Weiche Backe / Soft jaw / Mors doux**

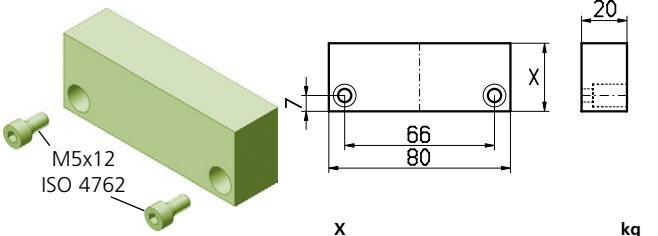

	x	kg
CC 8030	30	~ 0,35
CC 8050	50	~ 0,59

**Prismabacke / Prismatic jaw / Mors avec prisme**

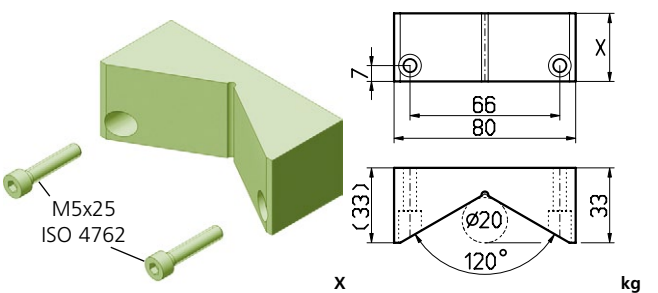

	x	kg
CC 8050 V120°	30	~ 0,41

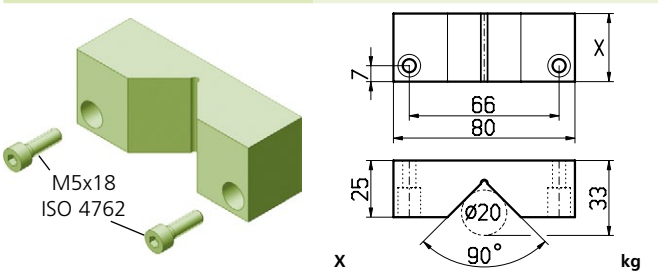

	x	kg
CC 8050 V90°	30	~ 0,38

**Backe mit 2 Pendeldruckstücken**

**Jaw with 2 swiveling balls**  
**Mors avec deux pièces de pression mobiles**

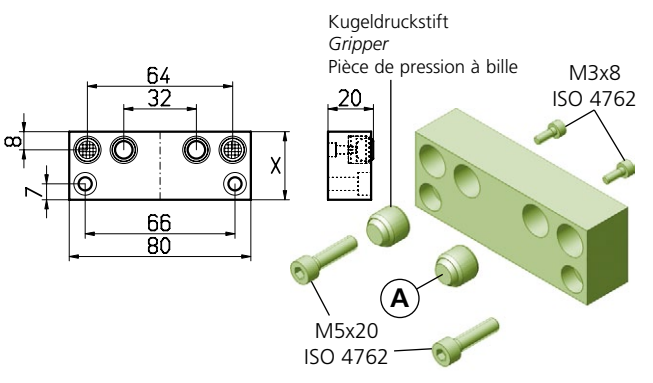

	A	x	kg
CC 8060		30	~ 0,30
CC 8060R		30	~ 0,30

**Backe für Druckstift**

**Jaw for pressure pin**  
**Mors pour pièce de pression**

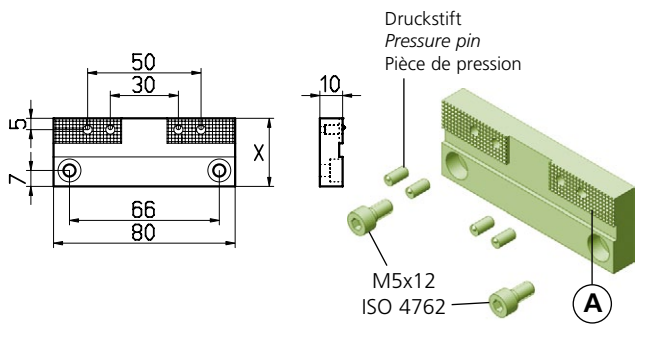

	A	x	kg
CC 8070		30	~ 0,17

**Backe / Jaw / Mors**

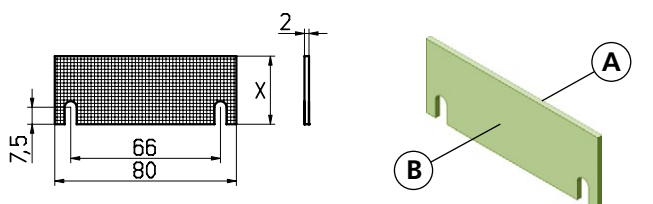

	A	B	x	kg
CC 8210			30	~ 0,03
CC 8211			30	~ 0,03

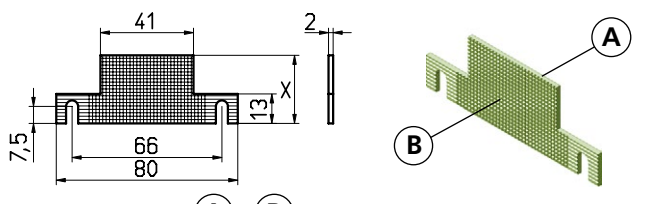

	A	B	x	kg
CC 8220			30	~ 0,02
CC 8221			30	~ 0,02