

**S656W** Tasouputinsarja laajentaa tasouputtimien käyttöaluetta ruuvikanta upotuksista myös syvempiin muotoihin.

Nämä 2-leikkuiset kovametallipaloin varustetut työkalut tekevät upottamisesta tehokasta ja taloudellista.

Halkaisija-alueet Ø11-50mm 0,5mm välein tarjoavat kattavan valikoiman työkaluja eri halkaisijoille.

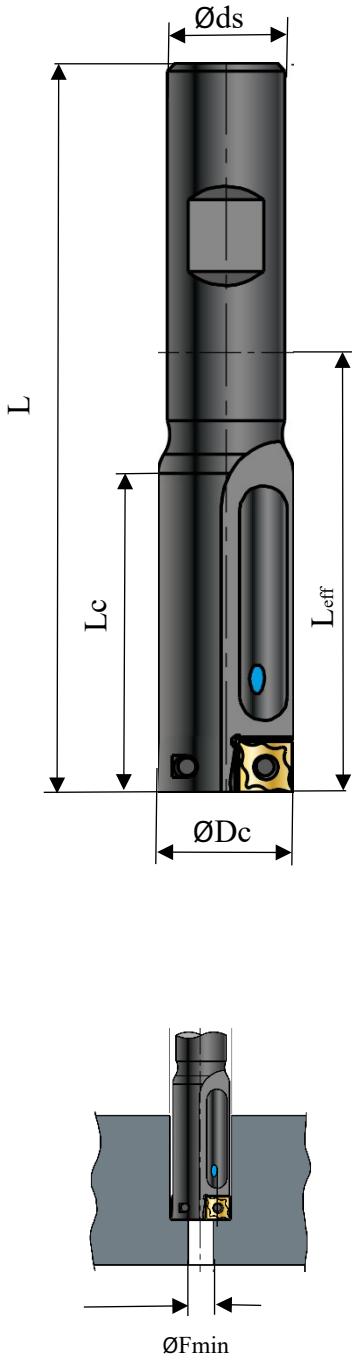

Tilauskoodi	ØDc	ØFmin	Øds	Lc	Leff	L	Teräpala
S656W 011.04	11	3,0	16	22	51	99	XCGT 0401...
S656W 011.5.04	11,5	3,5	16	22	51	99	XCGT 0401...
S656W 012.04	12	4,0	16	24	53	101	XCGT 0401...
S656W 012.5.04	12,5	4,5	16	24	53	101	XCGT 0401...
S656W 013.04	13	5,0	16	26	57	105	XCGT 0401...
S656W 013.5.04	13,5	5,5	16	26	57	105	XCGT 0401...
S656W 014.05	14	3,4	16	28	38	86	XCGT 0502...
S656W 014.5.05	14,5	3,9	16	28	38	86	XCGT 0502...
S656W 015.05	15	4,5	16	30	40	88	XCGT 0502...
S656W 015.5.05	15,5	5,0	16	30	40	88	XCGT 0502...
S656W 016.06	16	4,1	16	32	44	92	XCGT 0602...
S656W 016.5.06	16,5	4,6	16	32	44	92	XCGT 0602...
S656W 017.06	17	5,1	16	35	46	94	XCGT 0602...
S656W 017.5.07	17,5	3,4	16	35	48	96	XCGT 0703...
S656W 018.07	18	3,9	16	36	49	97	XCGT 0703...
S656W 018.5.07	18,5	4,4	16	36	49	97	XCGT 0703...
S656W 019.07	19	4,9	16	38	52	100	XCGT 0703...
S656W 019.5.07	19,5	5,4	16	38	52	100	XCGT 0703...
S656W 020.08	20	4,2	16	40	54	102	XCGT 0803...
S656W 020.5.08	20,5	4,7	16	40	54	102	XCGT 0803...
S656W 021.08	21	5,2	20	42	64	114	XCGT 0803...
S656W 021.5.08	21,5	5,7	20	42	64	114	XCGT 0803...
S656W 022.09	22	4,0	20	44	66	116	XCGT 09T3...
S656W 022.5.09	22,5	4,5	20	44	66	116	XCGT 09T3...
S656W 023.09	23	5,0	20	46	69	119	XCGT 09T3...
S656W 023.5.09	23,5	5,5	20	46	69	119	XCGT 09T3...

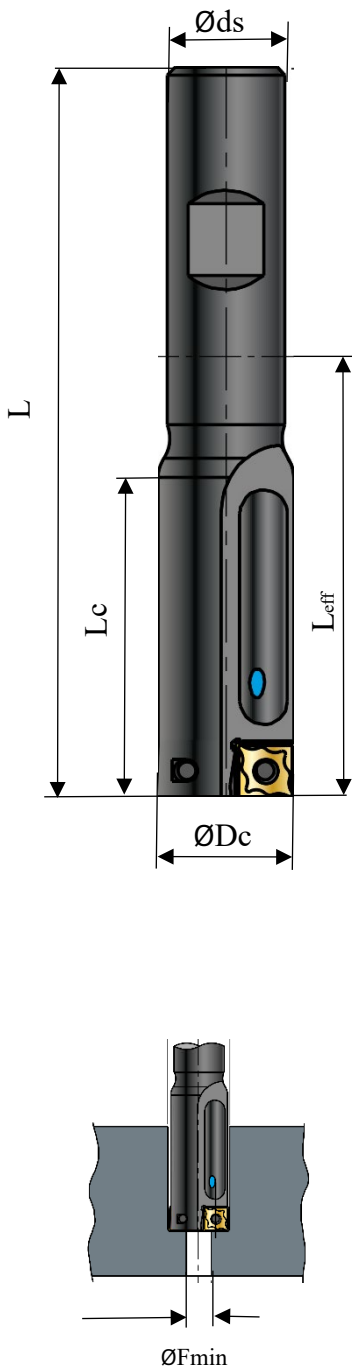

Tilauskoodi	ØDc	ØFmin	Øds	Lc	Leff	L	Teräpala
S656W 024.10	24	4,0	20	48	72	122	XCGT 10T3...
S656W 024.5.10	24,5	4,5	20	48	72	122	XCGT 10T3...
S656W 025.10	25	5,0	20	50	75	125	XCGT 10T3...
S656W 025.5.10	25,5	5,5	20	50	75	125	XCGT 10T3...
S656W 026.10	26	6,0	25	52	80	136	XCGT 10T3...
S656W 026.5.10	26,5	6,5	25	52	80	136	XCGT 10T3...
S656W 027.10	27	7,0	25	54	83	139	XCGT 10T3...
S656W 027.5.10	27,5	7,5	25	54	83	139	XCGT 10T3...
S656W 028.10	28	8,0	25	56	86	142	XCGT 10T3...
S656W 028.5.10	28,5	8,5	25	56	86	142	XCGT 10T3...
S656W 029.10	29	9,0	25	58	88	144	XCGT 10T3...
S656W 029.5.10	29,5	9,5	25	58	88	144	XCGT 10T3...
S656W 030.10	30	10,0	25	58	90	146	XCGT 10T3...
S656W 030.5.10	30,5	10,5	25	58	90	146	XCGT 10T3...
S656W 031.13	31	5,3	25	62	93	149	XCGT 1304...
S656W 031.5.13	31,5	5,8	25	62	93	149	XCGT 1304...
S656W 032.13	32	6,3	25	64	96	152	XCGT 1304...
S656W 032.5.13	32,5	6,8	25	64	96	152	XCGT 1304...
S656W 033.13	33	7,2	32	66	103	163	XCGT 1304...
S656W 033.5.13	33,5	7,7	32	66	103	163	XCGT 1304...
S656W 034.13	34	8,2	32	68	107	167	XCGT 1304...
S656W 034.5.13	34,5	8,7	32	68	107	114	XCGT 1304...
S656W 035.13	35	9,2	32	70	109	169	XCGT 1304...
S656W 035.5.13	35,5	9,7	32	70	109	169	XCGT 1304...
S656W 036.13	36	10,2	32	70	109	169	XCGT 1304...
S656W 036.5.13	36,5	10,7	32	70	109	169	XCGT 1304...
S656W 037.13	37	11,2	32	70	109	169	XCGT 1304...
S656W 037.5.13	37,5	11,7	32	70	109	169	XCGT 1304...
S656W 038.13	38	12,2	32	70	110	170	XCGT 1304...
S656W 038.5.13	38,5	12,7	32	70	110	170	XCGT 1304...
S656W 039.17	39	6,2	32	70	111	171	XCGT 1705...
S656W 039.5.13	39,5	6,7	32	70	111	171	XCGT 1705...

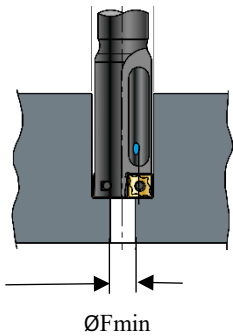
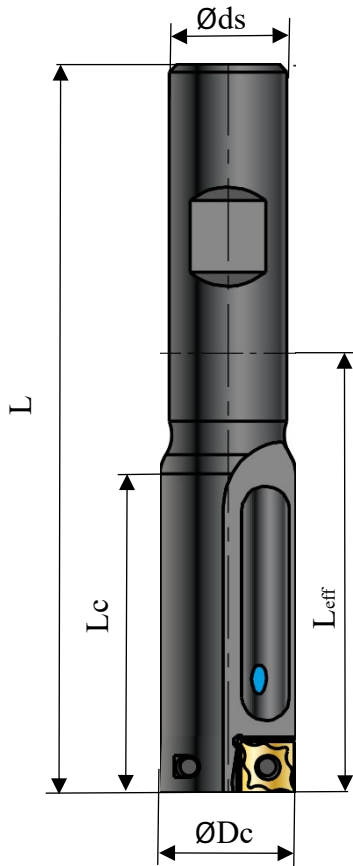

Tilauskoodi	ØDc	ØFmin	Øds	Lc	L <sub>eff</sub>	L	Teräpala
S656W 040.17	40	7,2	32	70	112	172	XCGT 1705...
S656W 040.5.17	40,5	7,7	32	70	112	172	XCGT 1705...
S656W 041.17	41	8,2	32	70	113	173	XCGT 1705...
S656W 041.5.17	41,5	8,7	32	70	113	173	XCGT 1705...
S656W 042.17	42	9,2	32	70	114	174	XCGT 1705...
S656W 042.5.17	42,5	9,7	32	70	114	174	XCGT 1705...
S656W 043.17	43	10,2	32	80	126	186	XCGT 1705...
S656W 043.5.17	43,5	10,7	32	80	126	186	XCGT 1705...
S656W 044.17	44	11,2	32	80	126	186	XCGT 1705...
S656W 044.5.17	44,5	11,7	32	80	126	186	XCGT 1705...
S656W 045.17	45	12,2	32	80	127	187	XCGT 1705...
S656W 045.5.17	45,5	12,7	32	80	127	187	XCGT 1705...
S656W 046.17	46	13,2	32	80	127	187	XCGT 1705...
S656W 046.5.17	46,5	13,7	32	80	127	187	XCGT 1705...
S656W 047.17	47	14,2	32	80	127	187	XCGT 1705...
S656W 047.5.17	47,5	14,7	32	80	127	187	XCGT 1705...
S656W 048.17	48	15,2	32	80	128	188	XCGT 1705...
S656W 048.5.17	48,5	15,7	32	80	128	188	XCGT 1705...
S656W 049.17	49	16,2	32	80	128	188	XCGT 1705...
S656W 049.5.17	49,5	16,7	32	80	128	188	XCGT 1705...
S656W 050.17	50	17,2	32	80	128	188	XCGT 1705...

### Teräpalat



#### XCGT .....-NP57P N3610

Käyttöalue: Alumiinit ja ei rautametallit



#### XCGT .....-N53 T2330

Käyttöalue: Ruostumattomat teräkset



#### XCNT .....-N54 F5120

Käyttöalue: Teräkset ja valuraudat



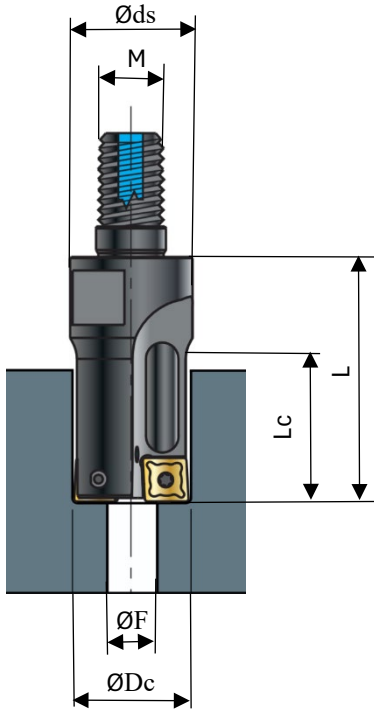

Tilaukoodi	ØDc	ØFmin	Øds	M	Lc	L	Teräpala
S659W 011.04	11	3,0	13	8	15	26	XCGT 0401...
S659W 012.04	12	4,0	13	8	16	27	XCGT 0401...
S659W 013.04	13	5,0	13	8	17	28	XCGT 0401...
S659W 014.05	14	3,4	18	10	18,6	33	XCGT 0502...
S659W 015.05	15	4,5	18	10	19,6	34	XCGT 0502...
S659W 016.06	16	4,1	18	10	20	35	XCGT 0602...
S659W 017.06	17	5,1	18	10	21	36	XCGT 0602...
S659W 018.07	18	3,9	21	12	23	38	XCGT 0703...
S659W 019.07	19	4,9	21	12	24	39	XCGT 0703...
S659W 020.08	20	4,2	21	12	25	40	XCGT 0803...
S659W 021.08	21	5,2	21	12	26	41	XCGT 0803...
S659W 022.09	22	4,0	29	16	28	47	XCGT 09T3...
S659W 023.09	23	5,0	29	16	29	48	XCGT 09T3...
S659W 024.10	24	4,0	29	16	30	50	XCGT 10T3...
S659W 025.10	25	5,0	29	16	31	51	XCGT 10T3...
S659W 026.10	26	6,0	29	16	32	52	XCGT 10T3...
S659W 027.10	27	7,0	29	16	33	53	XCGT 10T3...
S659W 028.10	28	8,0	29	16	34	54	XCGT 10T3...
S659W 029.10	29	9,0	29	16	35	55	XCGT 10T3...
S659W 030.10	30	10,0	29	16	36	56	XCGT 10T3...

Ruuviliitoskiinnitteiset tasoupottimet voidaan kiinnittää vakio-ruuviliitospitimiin, kuten DIJET lieriövartisiin täyskovametallivarsiin, tai suoraan työkalukartioihin joissa on ruuviliitoskiinnitys. Näin saadaan tehtyä pitkiä jäykkiä tasoupottimia esimerkiksi vaakakaraisten koneistuskeskusten käyttöön.

Pitkällä työkalulla voidaan väistää kiinnittimen muotoja, tai tehdä valukappaleen sisälle upotuksia jne. Suoraan työkalukartioon kiinnityksellä voidaan työkalun pituutta optimoida tukevuuden takaamiseksi.

Kerromme mielellämme lisää FMS-Toolsilla ja autamme löytämään juuri oikean työkalun jokaiseen kohteeseen.

