

WEXO[®]
KOMPETENZ IN PRÄZISION



RatioTap[®]

DIE ALTERNATIVE
The alternative
L'alternative
L'alternativa

PROMO
SET 10

1.4. – 30.9.2021

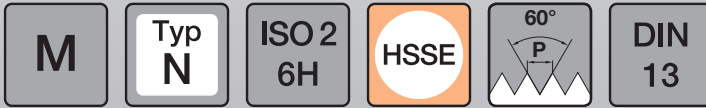

M

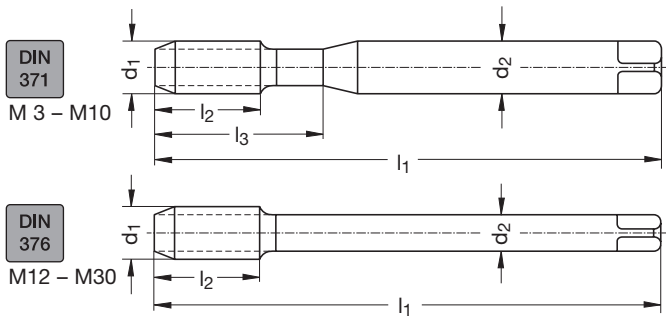

HSSE

Katalog-Nr. Catalogue n°	Catalogue no. Nr. di catalogo	NB00		NB00VP		NB00TI											
		-		VP		TiN											
d ₁ [mm]	P [mm]	l ₁ [mm]	l ₂ [mm]	l ₃ [mm]	d ₂ [mm]	□ [mm]	z	∅ [mm]	Code	€ Set*	€ Set*	Code	€ Set*	€ Set*	Code	€ Set*	€ Set*
M 3	0,5	56	9	18	3,5	2,7	3	2,5	GAV 600 000	80,50	48,30	GAV 601 000	80,50	48,30	GAV 602 000	137,50	82,50
M 4	0,7	63	12	21	4,5	3,4	3	3,3	GAV 600 002	80,50	48,30	GAV 601 002	80,50	48,30	GAV 602 002	137,50	82,50
M 5	0,8	70	13	25	6	4,9	3	4,2	GAV 600 003	83,50	50,10	GAV 601 003	83,50	50,10	GAV 602 003	142,50	85,50
M 6	1	80	15	30	6	4,9	3	5	GAV 600 004	83,50	50,10	GAV 601 004	83,50	50,10	GAV 602 004	142,50	85,50
M 8	1,25	90	18	35	8	6,2	3	6,8	GAV 600 006	110,00	66,00	GAV 601 006	110,00	66,00	GAV 602 006	177,50	106,50
M 10	1,5	100	20	39	10	8	3	8,5	GAV 600 008	130,00	78,00	GAV 601 008	130,00	78,00	GAV 602 008	222,50	133,50
M 12	1,75	110	23	0	9	7	3	10,2	GAV 600 010	172,50	103,50	GAV 601 010	172,50	103,50	GAV 602 010	285,00	171,00

RatioTap[®]

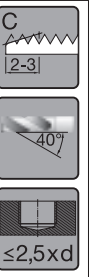
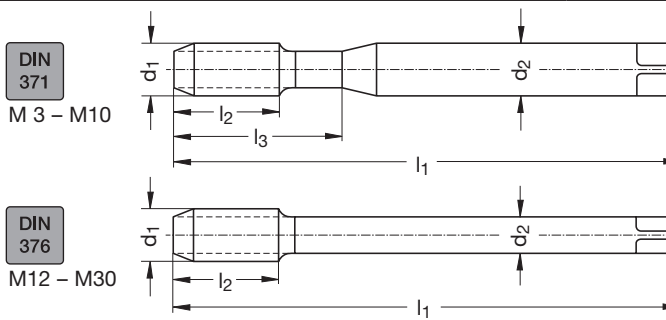

Katalog-Nr. Catalogue n°	Catalogue no. Nr. di catalogo	NC40		NC40VP		NC40TI											
		-		VP		TiN											
d ₁ [mm]	P [mm]	l ₁ [mm]	l ₂ [mm]	l ₃ [mm]	d ₂ [mm]	□ [mm]	z	∅ [mm]	Code	€ Set*	€ Set*	Code	€ Set*	€ Set*	Code	€ Set*	€ Set*
M 3	0,5	56	5	18	3,5	2,7	3	2,5	GAV 600 100	86,00	51,60	GAV 601 100	86,00	51,60	GAV 602 100	145,00	87,00
M 4	0,7	63	7	21	4,5	3,4	3	3,3	GAV 600 102	86,00	51,60	GAV 601 102	86,00	51,60	GAV 602 102	145,00	87,00
M 5	0,8	70	8	25	6	4,9	3	4,2	GAV 600 103	86,00	51,60	GAV 601 103	86,00	51,60	GAV 602 103	145,00	87,00
M 6	1	80	10	30	6	4,9	3	5	GAV 600 104	86,00	51,60	GAV 601 104	86,00	51,60	GAV 602 104	145,00	87,00
M 8	1,25	90	13	35	8	6,2	3	6,8	GAV 600 106	117,50	70,50	GAV 601 106	117,50	70,50	GAV 602 106	185,00	111,00
M 10	1,5	100	15	39	10	8	3	8,5	GAV 600 108	137,50	82,50	GAV 601 108	137,50	82,50	GAV 602 108	230,00	138,00
M 12	1,75	110	18	0	9	7	3	10,2	GAV 600 110	185,00	111,00	GAV 601 110	185,00	111,00	GAV 602 110	300,00	180,00

- * 1 Set = 10 Stück; keine Einzelabgabe möglich
- * 1 set = 10 tools; no single delivery possible
- * 1 set = 10 outils; pas de livraison à l'unité possible
- * 1 set = 10 utensili; non è possibile ordinarli singolarmente

Alle Preise sind Netto-Endpreise und gelten bis 30. September 2021.
All prices are net final prices. They are valid to September 30, 2021.
Tous les prix sont des prix nets. Valable au 30 septembre 2021.
Tutti prezzi sono finali netti. Valido al 30 settembre 2021.



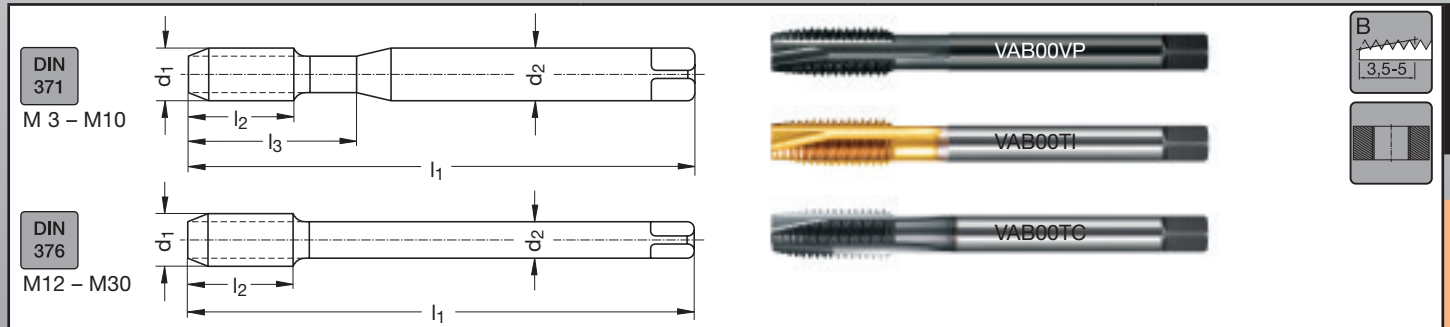
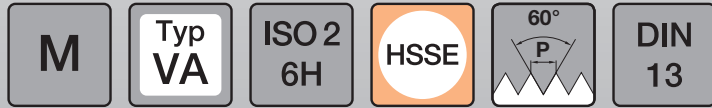

Katalog-Nr. Catalogue n°		Catalogue no. Nr. di catalogo								VAB00VP			VAB00TI			VAB00TC		
d ₁	P	l ₁	l ₂	l ₃	d ₂	□	z	∅	Code	€Set*	€Set*	Code	€Set*	€Set*	Code	€Set*	€Set*	
M 3	0,5	56	9	18	3,5	2,7	3	2,5	GAV 601 020	91,50	54,90	GAV 602 020	150,00	90,00	GAV 603 020	155,00	93,00	
M 4	0,7	63	12	21	4,5	3,4	3	3,3	GAV 601 022	91,50	54,90	GAV 602 022	150,00	90,00	GAV 603 022	155,00	93,00	
M 5	0,8	70	13	25	6	4,9	3	4,2	GAV 601 023	91,50	54,90	GAV 602 023	150,00	90,00	GAV 603 023	155,00	93,00	
M 6	1	80	15	30	6	4,9	3	5	GAV 601 024	91,50	54,90	GAV 602 024	150,00	90,00	GAV 603 024	155,00	93,00	
M 8	1,25	90	18	35	8	6,2	3	6,8	GAV 601 026	122,50	73,50	GAV 602 026	190,00	114,00	GAV 603 026	200,00	120,00	
M 10	1,5	100	20	39	10	8	3	8,5	GAV 601 028	145,00	87,00	GAV 602 028	237,50	142,50	GAV 603 028	245,00	147,00	
M 12	1,75	110	23	0	9	7	3	10,2	GAV 601 030	190,00	114,00	GAV 602 030	300,00	180,00	GAV 603 030	310,00	186,00	

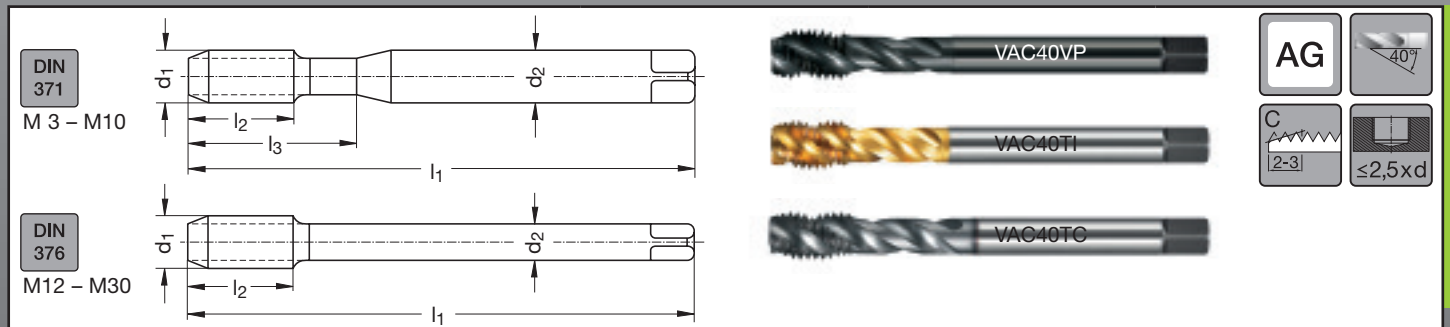

Katalog-Nr. Catalogue n°		Catalogue no. Nr. di catalogo								VAC40VP			VAC40TI			VAC40TC		
d ₁	P	l ₁	l ₂	l ₃	d ₂	□	z	∅	Code	€Set*	€Set*	Code	€Set*	€Set*	Code	€Set*	€Set*	
M 3	0,5	56	5	18	3,5	2,7	3	2,5	GAV 601 120	95,50	57,30	GAV 602 120	152,50	91,50	GAV 603 120	157,50	94,50	
M 4	0,7	63	7	21	4,5	3,4	3	3,3	GAV 601 122	95,50	57,30	GAV 602 122	152,50	91,50	GAV 603 122	157,50	94,50	
M 5	0,8	70	8	25	6	4,9	3	4,2	GAV 601 123	98,50	59,10	GAV 602 123	155,00	93,00	GAV 603 123	160,00	96,00	
M 6	1	80	10	30	6	4,9	3	5	GAV 601 124	98,50	59,10	GAV 602 124	155,00	93,00	GAV 603 124	160,00	96,00	
M 8	1,25	90	13	35	8	6,2	3	6,8	GAV 601 126	125,00	75,00	GAV 602 126	195,00	117,00	GAV 603 126	205,00	123,00	
M 10	1,5	100	15	39	10	8	3	8,5	GAV 601 128	147,50	88,50	GAV 602 128	240,00	144,00	GAV 603 128	247,50	148,50	
M 12	1,75	110	18	0	9	7	3	10,2	GAV 601 130	195,00	117,00	GAV 602 130	305,00	183,00	GAV 603 130	315,00	189,00	

* 1 Set = 10 Stück; keine Einzelabgabe möglich

* 1 set = 10 tools; no single delivery possible

* 1 set = 10 outils; pas de livraison à l'unité possible

* 1 set = 10 utensili; non è possibile ordinarli singolarmente

Alle Preise sind Netto-Endpreise und gelten bis 30. September 2021.

All prices are net final prices. They are valid to September 30, 2021.

Tous les prix sont des prix nets. Valable au 30 septembre 2021.

Tutti prezzi sono finali netti. Valido al 30 settembre 2021.



M

HSSE

RatioTap[®]



WEXO® Präzisionswerkzeuge GmbH

Siemensstraße 13, 61352 Bad Homburg (Germany)
T +49(0)6172 106-206, F +49(0)6172 106-213
<http://www.wexo.com> · E-Mail: verkauf@wexo.com